

Series 310

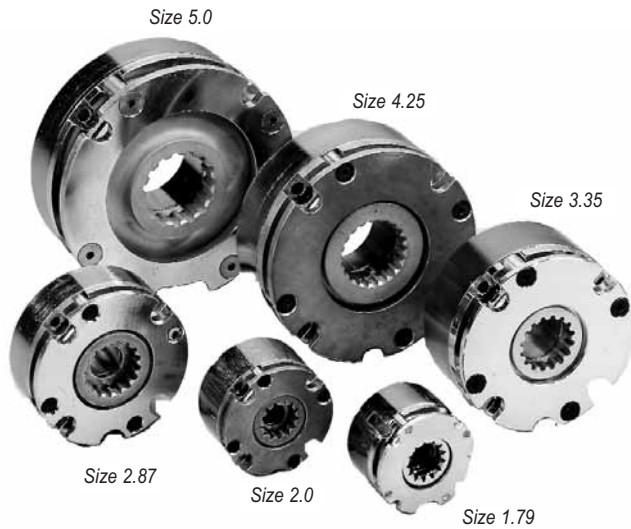

- Torque: 10 to 350 lb-in (1.1 to 39.5 Nm)
- UL Recognized Class H coil insulation system to US Standards (UR) and Canadian National Standards (CUR) - File E125303
- Spring activated and DC voltage released
- High torque, Compact size
- Corrosion resistant finishes
- Standard voltages 24 and 90 Vdc
115 and 230 Vac
- Available voltages 12, 36, 48 and 180 Vdc
- Low inertia rotating parts
- Splined hub for quiet dependable operation
- Holding applications only
- **Installation and Service Instructions:**
P/N 8-078-888-00

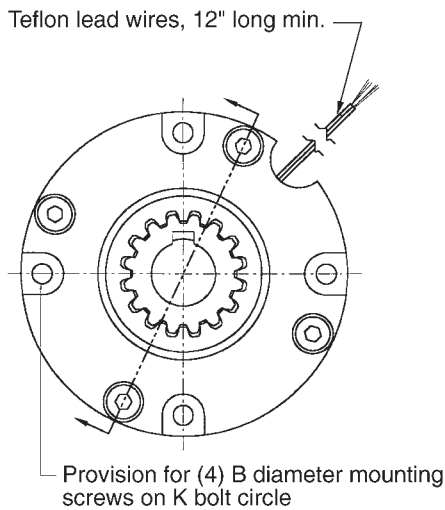

Option A, Long Hub

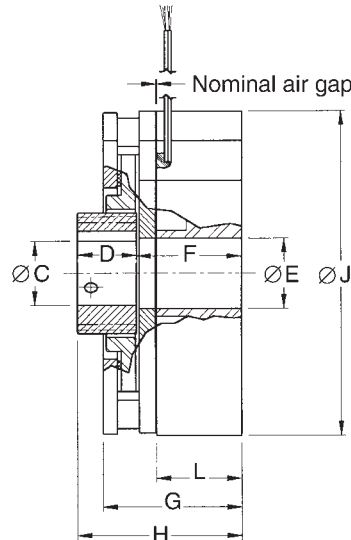

Dimensional Data

Size	Model Number	Mounting Screw		ØC Maximum	D Hub Lengths		E	Hub Location		G	H Overall & Long Hub	J	L Mounting Screw thru Mag. Body
		B	K		Long Hub	Short Hub		F					
1.79	310-24010	#2 (M2)	Ø1.640 (41.656)	5/16 (8mm)	.406 (10.31)	.202 (5.13)	.575 (14.61)	.958 (24.33)	1.185 (30.10)	1.364 (34.65)	1.79 (45.47)	.354 (9)	
	310-25010							1.325 (33.66)	1.470 (37.34)				
2.0	310-34010	#6 (M3)	Ø1.770 (44.958)	5/16 (8mm)	.406 (10.31)	.202 (5.13)	.425 (10.80)	.983 (243.97)	1.190 (30.23)	1.389 (35.28)	2.00 (50.80)	.845 (21.5)	
2.87	310-44010	#8 (M4)	Ø2.500 (63.500)	5/8 (15mm)	.520 (13.21)	.270 (6.86)	.625 (15.88)	.919 (23.34)	1.220 (30.99)	1.439 (36.55)	2.87 (72.89)	.750 (19)	
3.35	310-54010	#10 (M5)	Ø2.913 (73.990)	5/8 (15mm)	.700 (17.78)	---	1.125 (28.58)	1.015 (25.78)	1.630 (41.40)	1.927 (48.95)	3.35 (85.09)	1.086 (27.6)	
4.25	310-64010	1/4 (M6)	Ø3.750 (95.250)	7/8 (22mm)	.700 (17.78)	---	1.500 (38.10)	1.015 (25.78)	1.752 (44.50)	2.036 (51.7)	4.25 (107.95)	1.085 (27.6)	
5.0	310-74010	1/4 (M6)	Ø4.500 (114.300)	15/16 (24mm)	.800 (20.32)	---	1.750 (44.45)	1.015 (25.78)	1.905 (48.39)	2.187 (55.55)	5.00 (127.00)	1.062 (27)	

Series 310 Continued

Engineering Specifications/Pricing (Discount Symbol R1)

Size	Part Number	Nominal Static Torque		Friction Material Type	Approximate Weight		Electric Power (watts)	Hub and Disc Inertia		List Price
		lb-in	Nm		lbs	kg		lb-in-sec ²	kg-cm-sec ²	
1.79	310-24010-XX-XX	10	1.13	Holding	.5	0.23	13	1.7275E-05	1.9876E-05	\$246.00
	310-25010-XX-XX	13	1.47							\$266.00
2.0	310-34010-XX-XX	18	2.03	Holding	.7	.32	17	1.6150E-05	1.8582E-05	\$294.00
2.87	310-44010-XX-XX	40	4.52	Holding	1.5	.68	17	1.1150E-04	1.2829E-04	\$328.00
3.35	310-54010-XX-XX	140	15.8	Holding	3	1.36	22	1.6047E-04	1.8464E-04	\$397.00
4.25	310-64010-XX-XX	200	22.5	Holding	4.5	2.04	26	6.4099E-04	7.3751E-04	\$474.00
5.0	310-74010-XX-XX	350	39.5	Holding	6.6	2.99	19	1.9996E-03	2.3007E-03	\$620.00

Ordering Information

Group "3" Armature Acting Brake ——— 310-24010-0H-JA — Options – TABLE 3
 3-10: For AAB-S Models ———

AAB-S Unit Sizes	Part Number
1.79	2
2.0	3
2.87	4
3.35	5
4.25	6
5.0	7

5=Higher Torque
 4=Standard Torque
 3=Reduced Torque

Character	Options	Available by size
0	standard brake	ALL
H	Quiet operation, plastic carrier disc	1.79, 2.0, 2.87, 3.35*, 4.25*

*With carrier disc option, size 3.35 torque is 50 lb-in holding, and size 4.25 torque is 100 lb-in holding

Numeral or Letter	Options
1	Standard Unit

Numeral	Enclosure type
0	None

Table 1: hub bores 310-24010 - *[*] -JA

Character to insert	Bore +001/.001	Keyway Size		Bores Available (Size)					
		Width inches	Depth inches	1.79	2.0	2.87	3.35	4.25	5.0
0D	1/4	1/16	1/32	X	X				
0F	5/16	1/16	1/32	X	X				
0H	3/8	3/32	3/64	X	X	X			
0J	1/2	1/8	1/16			X	X		
0L	5/8	3/16	3/32			X	X	X	X
0N	3/4	3/16	3/32					X	X
0O	7/8	3/16	3/32					X	X
0P	15/16	1/4	1/8						X
	<i>Metric</i>	<i>mm</i>	<i>mm</i>						
06	6	2	1	X	X				
07	7	2	1	X	X				
08	8	2	1	X	X				
09	9	3	1.4			X			
10	10	3	1.4			X			
11	11	4	1.8			X			
12	12	4	1.8			X			
14	14	5	2.3			X	X	X	
15	15	5	2.3			X	X	X	
17	17	5	2.3					X	X
18	18	6	2.8					X	X
19	19	6	2.8					X	X
20	20	6	2.8					X	X
22	22	6	2.8					X	X
23	23	8	3.3						X
24	24	8	3.3						X

NOTE: Non-standard bore sizes available, contact factory. Add \$60.00 for non-standard bore size.

Table 2: Coil Voltage 310-24010-0H-[*]A

Character to insert	Voltage	List Adder	Current Rating in amps						
			1.79	2.0	2.87	3.35	4.25	5.0	
C	*12 Vdc	\$20.00	1.01	1.10	1.29	1.82	1.76	1.26	
E	24 Vdc	—	.51	.55	.66	.93	.89	.64	
G	*48 Vdc	20.00	.27	.29	.35	.46	.54	.40	
J	90 Vdc	—	.13	.14	.16	.23	.22	.16	
L	*180 Vdc	20.00	.08	.09	.09	.13	.14	.11	
N	115 Vac	15.00	.11	.16	.16	.17	.25	.17	
P	230 Vac	15.00	.06	.08	.08	.09	.13	.09	

*These voltages are non-standard. Add \$20.00 for non-standard coil voltage.

Table 3: Options 310-24010-0H-J[*]

Character	Options	Available by size
A	Basic Brake, Magnet Body Mounted, Long Hub	1.79, 2.0, 2.87, 3.35* 4.25*, 5.0*

*Sizes 3.35, 4.25 and 5.0 have a pass-through hub.

Armature Actuated Brakes (AAB) Torque Selection

Select the proper torque rating based on horsepower and rpm (speed at the clutch or brake) using the *Torque Selection Chart* below. Based on 1.4 service factor.

For other service factors and speeds, use the formulas shown below.

Formula for TABLE 1

$$T = \frac{63,025 \times P}{N} \times SF$$

T = Static torque, lb-in.
 P = Horsepower, hp
 N = Shaft speed at brake, rpm
 SF = Service Factor
 63,025 = Constant

Formula for TABLE 2

$$T = \frac{5,252 \times P}{N} \times SF$$

T = Static torque, lb-ft.
 P = Horsepower, hp
 N = Shaft speed at brake, rpm
 SF = Service Factor
 5,252 = Constant

Caution: Do not use Table 1 to select brakes for overhauling or high inertial loads, or where a stop in specified time or distance is required. For these applications the total inertia of the load and power transmission system must be determined to make a brake selection. Refer to sections on torque and thermal ratings and determination.

NOTE: Series 310 and 311 for holding applications only.

TABLE 1

Series 320, 321, 322 Static Torque in lb-in. (Nm)

Motor hp	rpm									
	600	800	1000	1200	1500	1800	2000	2400	3000	3600
	Static Torque lb-in (Nm)									
1/20	18 (.203)	7 (.79)	7 (.79)	7 (.79)	3 (.34)	3 (.34)	3 (.34)	3 (.34)	3 (.34)	3 (.34)
1/12	18 (.203)	18 (2.03)	7 (.79)	7 (.79)	7 (.79)	7 (.79)	7 (.79)	3 (.34)	3 (.34)	3 (.34)
1/8	35 (3.95)	18 (2.03)	18 (2.03)	18 (2.03)	18 (2.03)	7 (.79)	7 (.79)	7 (.79)	7 (.79)	3 (.34)
1/6	35 (3.95)	35 (3.95)	18 (2.03)	18 (2.03)	18 (2.03)	18 (2.03)	18 (2.03)	7 (.79)	7 (.79)	7 (.79)
1/4	—	35 (3.95)	35 (3.95)	35 (3.95)	18 (2.03)	18 (2.03)	18 (2.03)	18 (2.03)	18 (2.03)	7 (.79)
1/3	—	—	35 (3.95)	35 (3.95)	35 (3.95)	18 (2.03)	18 (2.03)	18 (2.03)	18 (2.03)	18 (2.03)
1/2	—	—	—	—	35 (3.95)	35 (3.95)	35 (3.95)	35 (3.95)	18 (2.03)	18 (2.03)
3/4	—	—	—	—	—	—	35 (3.95)	35 (3.95)	35 (3.95)	35 (3.95)
1	—	—	—	—	—	—	—	—	—	35 (3.95)

TABLE 2

Series 333/350/360 Static Torque in lb-ft. (Nm)

Motor hp (kw)	rpm									
	600	800	1000	1200	1500	1800	2000	2400	3000	3600
	Static Torque lb-ft (Nm)									
1/3 (.25)	6 (8)	6 (8)	3 (4)	3 (4)	3 (4)	3 (4)	3 (4)	3 (4)	3 (4)	3 (4)
1/2 (.37)	12 (16)	6 (8)	6 (8)	6 (8)	3 (4)	3 (4)	3 (4)	3 (4)	3 (4)	3 (4)
3/4 (.55)	12 (16)	12 (16)	6 (8)	6 (8)	6 (8)	6 (8)	3 (4)	3 (4)	3 (4)	3 (4)
1 (.75)	25 (34)	12 (16)	12 (16)	12 (16)	6 (8)	6 (8)	6 (8)	6 (8)	6 (8)	3 (4)
1-1/2 (1.1)	25 (34)	25 (34)	12 (16)	12 (16)	12 (16)	12 (16)	6 (8)	6 (8)	6 (8)	6 (8)
2 (1.5)	25 (34)	25 (34)	25 (34)	25 (34)	12 (16)	12 (16)	12 (16)	6 (8)	6 (8)	6 (8)
3 (2.2)	45 (60)	45 (60)	25 (34)	25 (34)	25 (34)	25 (34)	12 (16)	12 (16)	12 (16)	12 (16)
5 (3.7)	60 (80)	60 (80)	45 (60)	45 (60)	25 (34)	25 (34)	25 (34)	25 (34)	25 (34)	12 (16)
7-1/2 (5.6)	110 (150)	110 (150)	60 (80)	60 (60)	45 (60)	45 (60)	45 (60)	25 (34)	25 (34)	25 (34)
10 (7.5)	180 (240)	110 (150)	110 (150)	110 (150)	60 (80)	45 (60)	45 (60)	45 (60)	25 (34)	25 (34)
15 (11.2)	300 (400)	180 (240)	110 (150)	110 (150)	110 (150)	60 (80)	60 (80)	60 (80)	45 (60)	45 (60)
20 (14.9)	300 (400)	180 (240)	180 (240)	180 (240)	110 (150)	110 (150)	110 (150)	60 (80)	60 (80)	60 (80)
25 (18.6)	—	300 (400)	180 (240)	180 (240)	180 (240)	110 (150)	*	*	*	*
30 (22.4)	—	300 (400)	300 (400)	300 (400)	180 (240)	180 (240)	*	*	*	*
40 (29.8)	—	—	300 (400)	300 (400)	300 (400)	180 (240)	*	*	*	*
50 (37.3)	—	—	—	—	300 (400)	300 (400)	*	*	*	*
60 (44.7)	—	—	—	—	300 (400)	300 (400)	*	*	*	*

* Exceeds maximum speed rating.

Stearns® Spring-Set Disc Brakes

Installation and Service Instructions for 310 and 311 Series AAB-S Holding Brakes Spring-Set Electrically Released

Important

Please read these instructions carefully before installing, operating, or servicing your Stearns brake. Failure to comply with these instructions could cause injury to personnel and/or damage to property if the brake is installed or operated incorrectly. For definition of limited warranty/liability, contact Rexnord Industries, LLC., Stearns Division, 5150 S. International Dr., Cudahy, Wisconsin 53110, (414) 272-1100.

OEM's and subsystem suppliers, please forward these instructions with your components to the final user.

Caution

1. Servicing shall be in compliance with applicable local safety codes including Occupational Safety and Health Act (OSHA). All wiring and electrical connections must comply with the National Electric Code (NEC) and local electric codes in effect.
2. To prevent an electrical hazard, disconnect power source before working on the brake. If power disconnect point is out of sight, lock disconnect in the *off* position and tag to prevent accidental application of power to system.
3. To avoid damage to the internal rectifier in the AC voltage versions of these brakes, hipot testing should not exceed 1500 volts for one second. Brake coil leads must be connected together during hipot.
4. Heat developed by the brake during normal operation may be hot enough to be painful or cause injury. Be careful when touching exterior surfaces. Allow sufficient time for the brake to cool before servicing.
5. After usage, the brake will contain burnt and degraded friction material dust. This dust should be removed before servicing or adjusting the brake.

DO NOT blow off dust using an air hose. It is important to avoid dispersing dust into the air or inhaling it, as this may be dangerous to your health.

- a) Wear a filtered mask or a respirator while removing dust.
- b) Use a vacuum cleaner or a soft brush to remove dust from the brake. When brushing, avoid causing the dust to become airborne. Collect the dust in a container, such as a bag, which can be sealed off.

Installation

The brake can be mounted on either face. With units mounting on the hub end, the hub should be secured to shaft before mounting brake. Two set screws are

provided in the hub and should be securely tightened against the motor shaft using the appropriate threadlocking adhesive as determined by testing in your application. Refer to Table B for the recommended set screw tightening torque when using an anaerobic adhesive threadlocking agent. The key should not extend towards the armature past the face of the hub. Refer to Table A for positioning of hub. Mount brake using screws or bolts and lock washers. The rated voltage should be available at the brake and allowance should be made for voltage drop in long wiring runs.

Note: Position of hub should allow full engagement of friction disc without interfering with the movement of the armature.

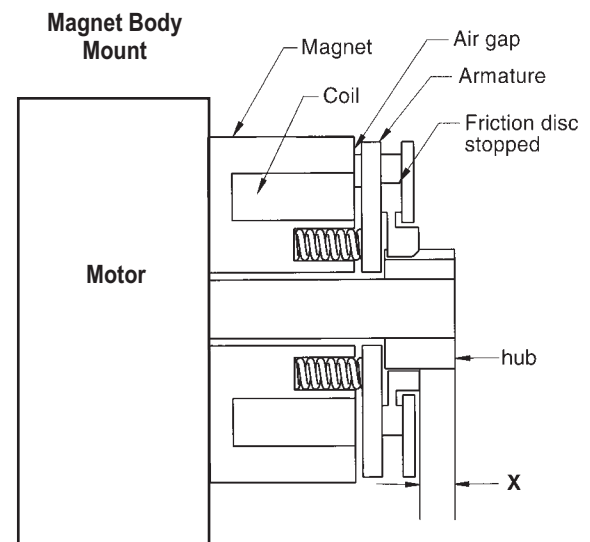

Pressure Plate Mount

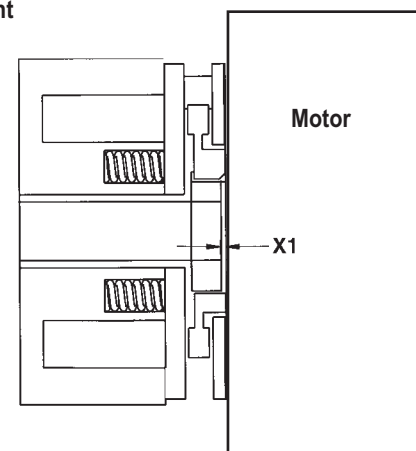

Table A: Hub Location and Air Gap

[BACK TO PRODUCT PAGE](#)

Model	"X" Hub Location inch (mm)	"X1" Hub Location (Min.) inch (mm)	Nominal Factory Air Gap* inch (mm)	Maximum Air Gap* inch (mm)	Set Screw Torque	Maximum Allowed Misalignment	
						Parallel	Angular
31024010XXXX	.135 (3.43)	.010 (.25)	.004 (1.102)	.015 (.381)	10 lb-in	.003	.003
31034010XXXX	.185 (4.70)	.010 (.25)	.005 (0.127)	.011 (.279)	10 lb-in	.003	.003
31044010XXXX	.227 (5.77)	.010 (.25)	.005 (0.127)	.011 (.279)	20 lb-in	.005	.005
31054010XXXX	.328 (8.33)	.010 (.25)	.005 (0.127)	.010 (.254)	20 lb-in	.005	.005
31064010XXXX	.328 (8.33)	.010 (.25)	.006 (0.153)	.014 (.356)	34 lb-in	.005	.005
31074010XXXX	.328 (8.33)	.010 (.25)	.006 (0.153)	.012 (.305)	34 lb-in	.005	.005
31154010XXXX	N/A	.38 to .28	.007 (0.778)	.030 (.762)	34 lb-in	.005	.005
31164010XXXX	N/A	.24 to .14	.008 (0.203)	.060 (1.53)	34 lb-in	.005	.005
31174010XXXX	N/A	.60 to .50	.008 (0.203)	.030 (.762)	78 lb-in	.005	.005

Table B: Series 310 Friction Disc and Hub Part Numbers

Part Description	Size/Model Number					
	Size 1.79 31024010XXXX	Size 2.0 31034010XXXX	Size 2.87 31044010XXXX	Size 3.35 31054010XXXX	Size 4.25 31064010XXXX	Size 5.0 31074010XXXX
Friction Disc	518170600	518201800	518204000	518331200	518420000	518530000
Brake Hub	51605170001*	51605170001*	51605280001*	51605330001*	51605420001*	51605500001*

*Specify Bore Size

Table C: Series 311 Friction Disc and Hub Part Numbers

Part Description	Size/Model Number		
	Size 3.35 31154010XXXX	Size 4.25 31164010XXXX	Size 5.0 31174010XXXX
Friction Disc	518311500	518311600	518311700
Brake Hub	51503000001*	51503100001*	51503200001*

Note: Contact Factory for other replacement parts

*Specify Bore Size

General

After proper installation, no further adjustment should be required for the life of the unit.

Power supply

The voltage to be applied is determined by rating shown on the nameplate. Resistance and other coil data for various voltages are tabulated on appropriate Engineering Data Sheets. This data can be secured by contacting the factory. Resistance readings are not possible with units that have internal or in-leadwire rectification.

Troubleshooting for AAB Brakes

Overheating, coil burned out or loss of torque

1. Check ambient temperature. It is above 40° C? Consult factory for assistance.
2. Check voltage supply as close to coil as feasible. Compare to nameplate data, if incorrect apply proper voltage.
3. Check that dirt particles have not collected between the magnet body and armature, causing incomplete separation between the armature and friction disc.

4. Is coil resistance correct? Consult factory for resistance of the specific coil.
5. Check for oil/grease on friction elements.
6. On pressure spring, check for broken, missing or substituted springs not of our design.
7. Failure to release after unit has performed satisfactorily for a period indicates wear has occurred. If air gap has exceeded maximum air gap specified in Table A, replace friction disc. See Table B or Table C for part numbers.

Fuse in DC power supply blows









1. Never put in a higher rating fuse or replace with a slo-blow type.
2. Check resistance of coil, if shorted, replace the brake. If not shorted, obtain coil resistance from factory and compare to your reading.
3. If cause was not found in Step 2 above, check power supply rectifier bridge by removing all loads and replacing fuse. If fuse blows when AC is applied to rectifier, bridge is shorted. Replace bridge if feasible or discard control and replace.



Armature Actuated Brake Modifications

[BACK TO PRODUCT PAGE](#)

Series 320/321/322

Modification	Series	Brake Size	List Price
Maintained Manual Release			
	320/321/322	1.2 1.8 2.0 2.8	\$25.00 \$30.00 \$30.00 \$30.00
Non-Maintained Manual Release			
	320/321/322	1.2 1.8 2.0 2.8	\$25.00 \$30.00 \$30.00 \$30.00
Brake Release Indicator Switch			
	320/321/322	ALL	\$40.00
AC Rectifiers, In-Line			
	310/320/321/322	ALL	\$25.00
AC Rectifiers, Internal	320/321/322	1.8 and 2.8	\$15.00
Encoder Mount			
	310/320/321/322 tapped holes in magnet body for tether mount		\$25.00
Through-Shaft			
	321/322	ALL (through-shaft combined with manual release only available on size 2.8)	\$5.00
Mounting Plates			
	320/321/322	Size	List Price
		1.2	\$20.00
		1.8, 2.8	\$15.00
		1.8, 2.8 3.5", 2.5" register	\$30.00
		2.0 2.844"	\$20.00
Double "D" Disc			
	320/321/322	1.2, 1.8, and 2.0 Contact factory for Double "D" disc on brakes rated greater than 7 lb-in	No charge
Carrier Ring Disc	320/321/322	1.8	\$10.00