

Shaft-Mounted Clutches

Product Overview

CCC Clutch Coupling

The compact CCC Clutch-Coupling offers a high torque-to-size ratio meeting a broad range of applications. Available in five sizes. CCC Clutch-Couplings can be used in almost any coupling application where on-off control of rotary motion is required. Available for 90-100, 24-28, or 12 Vdc operation.

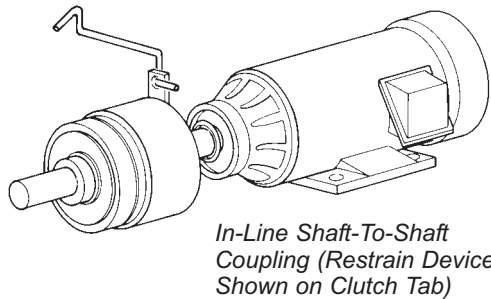

CRP Roto Sheave Clutches

The performance, quality, and life of this unit have been proven in thousands of applications. This one-piece, pre-aligned unit has an integral sheave for quick, convenient installation and maintenance. Available in four sizes from 100 lb-in to 1740 lb-in with a variety of standard sheaves. An ideal solution for almost any parallel shaft drive application. Available for 90-100, 24-28, or 12 Vdc operation.

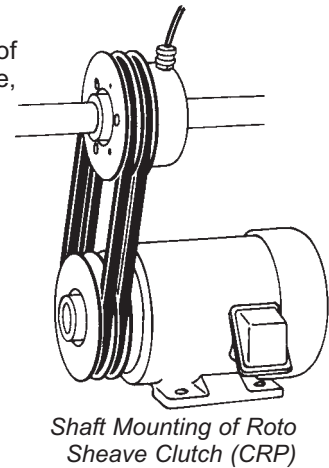

CRS Roto-Sprocket Clutch

An ideal solution for almost any parallel shaft drive application, this unit has been proven in thousands of applications. This one-piece, pre-aligned unit has a special adapter hub that accepts a plate-type sprocket. Installation and maintenance are quick and convenient. Available in four sizes, from 100 lb-in through 1740 lb-in nominal static torque.

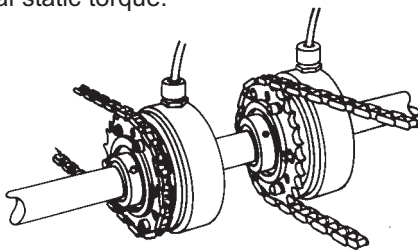

CTS Through-Shaft Clutch

The compact CTS Clutch offers a high torque-to-size ratio in an economical unit that meets a broad range of applications. Available in three sizes. Extended thru-shaft driven hub is adaptable for mounting pulleys, gears, or sprockets. CTS Clutches can be used in almost any parallel shaft application where on-off control of rotary motion is required. Available for 90-100, 24-28, or 12 Vdc operation.

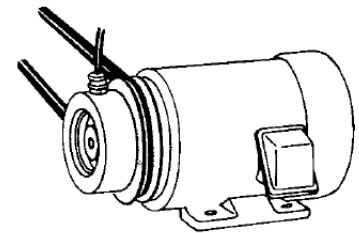

Stearns Shaft-mounted clutches can be ordered as a standard dc unit, with the option of a separate rectifier (see page 47 for information on rectifier packages), or as a Tor-ac unit which has a built-in rectifier.

Wiring of standard dc unit with optional ac rectifier

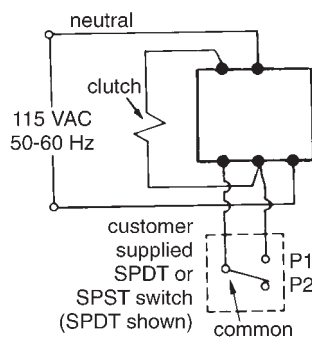

Wiring of Tor-ac unit with built-in rectifier

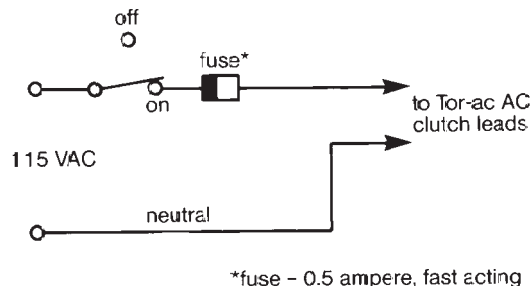

CCC Clutch-Clutch Coupling

- CSA certified
- Ball-bearing mounted stationary field for long trouble-free operation
- Spline drive for long life under heavy loads
- Available with spring release
- Available with case hardened armature
- Zinc plated magnet body for corrosion resistance
- Epoxy encapsulated coil construction for uniform heat transfer and moisture resistance
- Class H magnet wire and potting material

Installation and Service Instructions Sheet 8-078-800-00



Standard DC Clutch



Tor-ac Clutch with Built-In Rectifier

Dimensions are for estimating only and subject to change without notice. For installation purposes, request certified prints.

IMPORTANT NOTE: Information and dimensioning relating to Tor-ac units shown in shaded area.

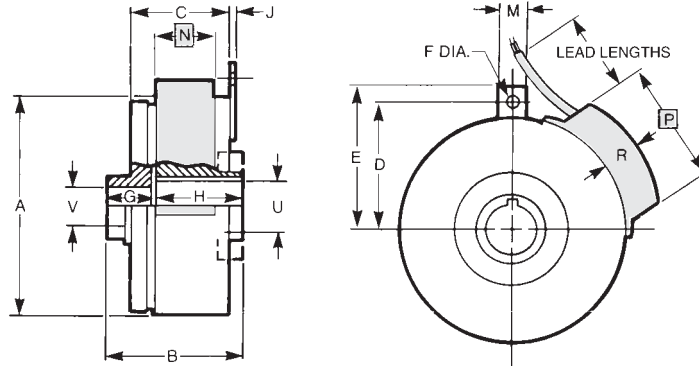

Dimensional Data (In Inches)

Size	A	B	C	D	E	F	G	H	J	M	N	P	R	U Bore (Drive Hub)	V Bore (Driven Hub)
3	2.67	2.04	1.40	1.56	1.75	.13	.63	1.35	.06	.50	—	—	—	1/4, 5/16, 3/8	1/4, 5/16, 3/8
3.5	3.19	2.14	1.49	1.81	2.00	.19	.63	1.44	.06	.66	1.00	2.74	.80	3/8, 1/2, 5/8	3/8, 1/2, 5/8, 3/4
5	4.31	2.66	1.78	2.50	2.84	.19	.81	1.71	.09	.50	1.00	2.81	.69	1/2, 5/8, 3/4, 7/8, 1	1/2, 5/8, 3/4, 7/8, 1
5.5	5.63	3.45	2.20	3.25	3.50	.25	1.16	2.17	.09	.75	1.00	2.93	.81	3/4, 7/8, 1, 1 1/8, 1 1/4	3/4, 7/8, 1, 1 1/8, 1 1/4
8	8.38	3.39	2.38	4.63	5.00	.34	1.50	1.50	.13	1.00	—	—	—	5/8, 7/8, 1, 1 1/4, 1 1/2, 1 5/8**	5/8, 7/8, 1, 1 1/4, 1 1/2, 1 5/8**

Lead Lengths: All Tor-ac units have 32" leads. Standard DC unit, sizes 3 through 5 have 18" leads. Sizes 5.5 and 8 have 24" leads*

*Sizes 5.5 and 8 have cable grip fitting and 2 conductor cable. **Size 8 has taper lock bushings.

Performance/List Price Data (Discount Symbol X-1)

Catalog Number	Size	Type	Part Number	Nominal Static Torque (lb-in)	Nominal Dynamic Torque at 1800 RPM (lb-in)	Max. RPM	Inertia		Thermal Capacity (ft-lb/min) ^①	Approx. Weight (lbs)	Max Power (watts)	List Price
							Driven Side (lb-ft ²)	Drive Side (lb-ft ²)				
CCC-30	3	standard	2-11-2502-00	60	40	7000	24 x 10 ⁻⁴	1.67 x 10 ⁻³	1650	2.5	9	\$1068.00
CCC-30S		spring rel.	2-11-2502-01									
CCC-35	3.5	standard	2-11-3141-00	100	65	5000	47 x 10 ⁻⁴	2.96 x 10 ⁻³	2750	3.5	11	1380.00
CCC-35S		spring rel.	2-11-3141-01									
CCC-35T	3.5	standard	2-11-3170-00	100	65	5000	47 x 10 ⁻⁴	2.96 x 10 ⁻³	2750	3.5	11	1564.00
CCC-35ST		spring rel.	2-11-3170-01									
CCC-50	5	standard	2-11-4266-00	275	160	5000	57 x 10 ⁻⁴	1.47 x 10 ⁻²	4400	5.4	14	1500.00
CCC-50S		spring rel.	2-11-4266-01									
CCC-50T	5	standard	2-11-4270-00	275	160	5000	57 x 10 ⁻⁴	1.47 x 10 ⁻²	4400	5.4	14	1686.00
CCC-50ST		spring rel.	2-11-4270-01									
CCC-55	5.5	standard	2-11-5501-01	720	400	3600	57 x 10 ⁻³	6.09 x 10 ⁻²	8250	12	26	2116.00
CCC-55S		spring rel.	2-11-5501-04									
CCC-55T	5.5	standard	2-11-5570-00	720	400	3600	57 x 10 ⁻³	6.09 x 10 ⁻²	8250	12	26	2302.00
CCC-55ST		spring rel.	2-11-5570-01									
CCC-80	8	standard	2-11-8333-01	1740	1160	3600	59 x 10 ⁻²	46.2 x 10 ⁻²	16500	32	35	3310.00
CCC-80S		spring rel.	2-11-8301-01									

① Thermal capacity rating is based on ambient temperature of 70°F at 1750 RPM.

List prices subject to change without notice.

Ordering Information

Example of a complete part number:

2-11-2502-00-H J N — 3/4 bore 3/16 x 3/32 keyway
 — 90-100 Vdc
 — 3/8 bore 3/32 x 3/64 keyway

Bore and Keyway Table*

Character	Sizes 3, 3.5, 5, 5.5													Size 8 (bushings)							
	D	F	H	I	J	K	L	N	O	Q	R	T	U	V	B	D	E	F	H	K	L
Bore/Shaft Dia. (in.)	1/4	5/16	3/8	1/2	1/2	5/8	5/8	3/4	7/8	1	1 1/8	1 1/4	1 3/8	1 1/2	5/8	7/8	1	1 1/8	1 1/4	1 1/2	1 5/8
Keyway (inches)	1/16 1/32	1/16 1/32	3/32 3/64	none	1/8 1/16	none	3/16 3/32	3/16 3/32	3/16 3/32	1/4 1/8	1/4 1/8	1/4 1/8	5/16 5/32	3/8 3/16	3/16 3/32	3/16 3/32	1/4 1/8	1/4 1/8	1/4 1/8	3/8 3/16	3/8 3/16

Voltage Table

Character	Voltage
C	12 Vdc
E	24-28 Vdc
J	90-100 Vdc
N*	115 Vac*

*Includes rectifier. Not available on sizes 3 and 8.

*Special or metric bores available, consult factory.

For Convenience, Safety and Energy Savings, Look to Stearns® Rectifier Controls.

Perfectly matched to Stearns DC actuated clutches, brakes or combination units, Stearns rectifier controls offer solid-state reliability that also takes into account important human use factors, making them easy to utilize and maintain.

Stearns rectifier controls are available in fixed or adjustable output models with compact housings to simplify installation.

For ultimate convenience, all wiring connections are readily

accessible. The PR Series even goes one step further, offering the ease of modular plug-in designs connecting directly to octal sockets.

For safety, all models offered are fused to provide protection against overload and feature an arc suppression circuit, minimizing arcing and extending contact life. In the PR Series, the internal fuse can be changed only by removing the rectifier from its socket - eliminating a potential shock hazard.

For energy savings, efficiency is built into Stearns rectifiers. The adjustable voltage output on the PR-33, for example, uses thyristor control for a low 4-watt power loss-87% less than some competitive units.

When you need reliable performance and more, look to Stearns rectifier controls.



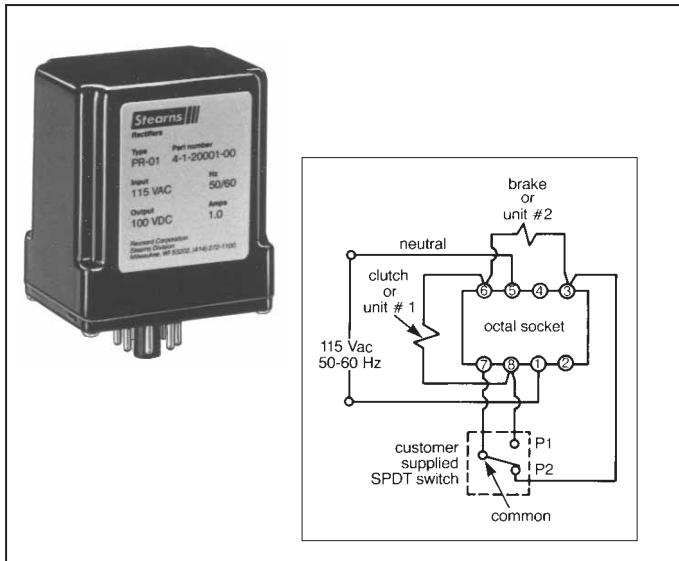

Rectifier Controls

Model PR-01

Two fixed 100 volt outputs.

- Modular plug-in design uses octal socket for easy mounting and wiring connection.
- Internally fused for overload protection.
- Operates one clutch or one brake, or both, one on at a time.

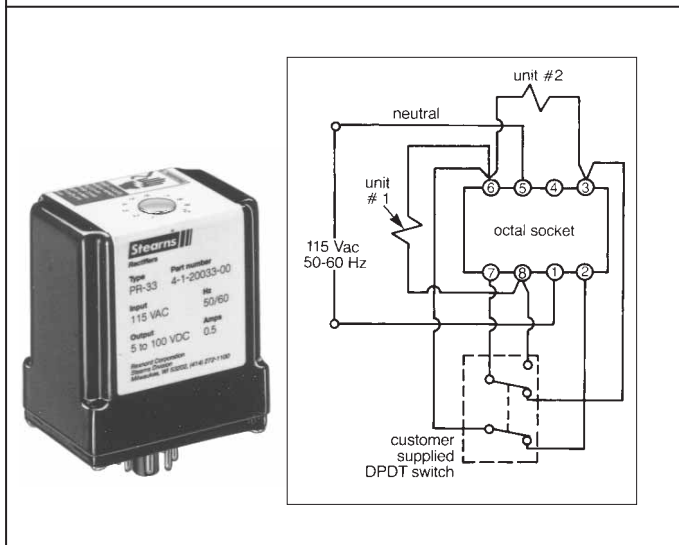

Model PR-33

One fixed 100 volt output and one adjustable 15-100 volt output to allow reduced torque starts or stops for "soft" cushioned engagement.

- Adjustable control on top of housing for easy accessibility.
- Modular plug-in design uses octal socket for each mounting and wiring connection.
- Internally fused for overload protection.
- Operates one clutch or one brake, or both, one on at a time.

Enclosure dimensions apply to both PR-01 and PR-33.

Performance/List Price Data

Rectifier Part Number	AC Input Voltage	Nominal DC Output			Control Circuits		Switching Relay	List Price ②	Discount Symbol
		Volts	Max. Amp①	Max. Watts	#1	#2			
PR-01 4-1-20001-00	115 50-60 Hz	100	1.0	100	Fixed	Fixed	No	\$266.00	X-1
PR-33 4-1-20033-00	115 50-60 Hz	15-100	0.5	50	Fixed	Variable	No	642.00	X-1

① Based on ambient temperature of 104°F.
② List prices subject to change without notice.

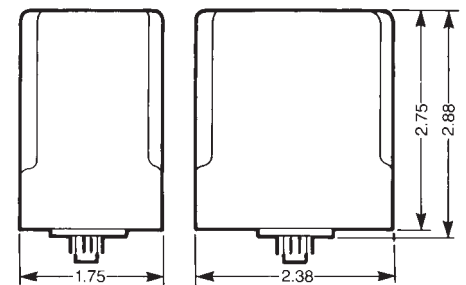

Octal Socket(s)

Supplied with terminal screws and clips



Part Number: 9-61-0153-00
Dimensions

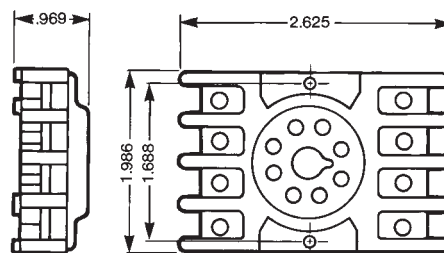

Part Number: 9-61-0153-01
Dimensions

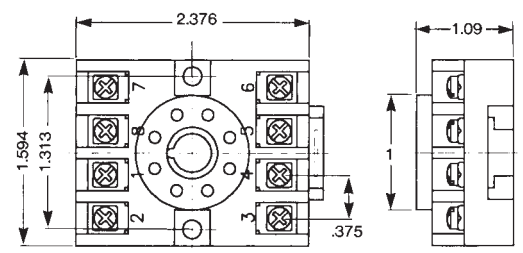

List Price Data

Octal Socket Part Number	List Price	Discount Symbol
9-61-0153-00	\$128.00	X-1
9-61-0153-01	48.00	X-1

Rectifier Controls

Series 12000 Silicon Rectifiers

Heavy duty single-phase rectifier for use with Stearns heavy duty clutches and brakes. Incorporates a solid-state silicon bridge circuit for high efficiency and excellent voltage regulation. Available with outputs of 115 or 230 Vdc; power ratings of up to 1150 watts. A transformer provides isolation and dual AC input capability... 115/230 or 230/460 Vac. Each rectifier is housed in a NEMA 1 steel cabinet and includes a separately housed manual starter with overload heaters.

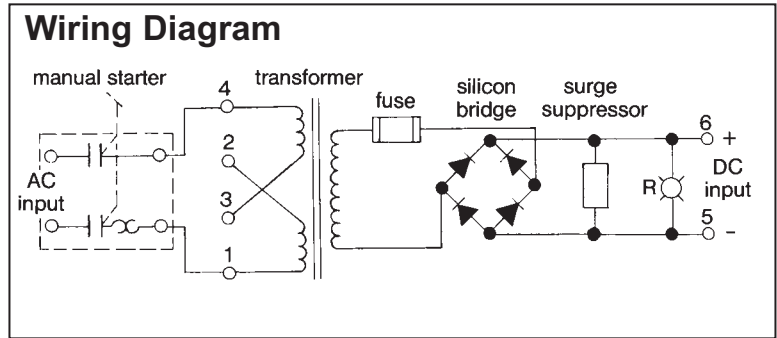

Dimensional Data

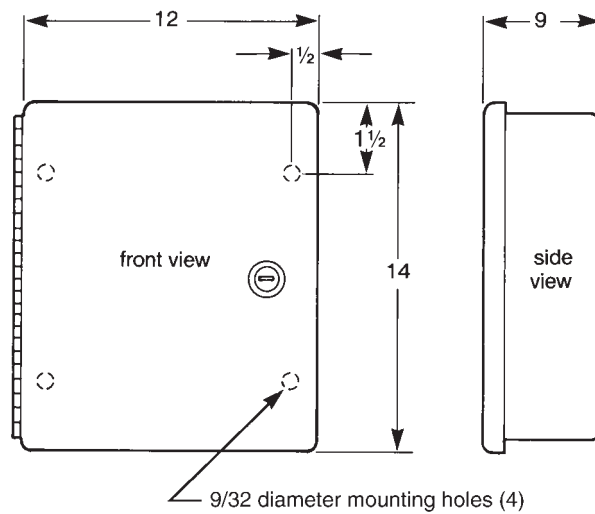

Performance Data

Stock Number	AC Input (50/60 Hz Single-Phase)		DC Output		
	Volts	Amps	Volts	Amps ^①	Watts
4-1-12102-00	115/230	2.5/1.3	115	2.0	230
4-1-12104-00	115/230	6.4/3.2	115	5.0	575
4-1-12202-00	230/460	1.3/0.7	115	2.0	230
4-1-12205-00	230/460	3.2/1.6	115	5.0	575
4-1-12302-00	115/230	5.2/2.6	230	2.0	460
4-1-12305-00	115/230	13.0/6.5	230	5.0	1150
4-1-12402-00	230/460	2.6/1.3	230	2.0	460
4-1-12405-00	230/460	6.4/3.2	230	5.0	1150

① Based on ambient temperature of 104°F.

Forcing Circuits

Combination forcing circuit and rectifier for use with Stearns SCE spring-set clutches and SCEB spring-set brakes. Suitable for use with all sizes from 800 through 1600. Provides the momentary forcing voltage necessary to release a clutch or brake. Units are available for 115, 208, 230, 460 and 575 Vac, 50/60 Hz input. The output of each unit is a forcing voltage of 230 Vdc which, after a 5 second delay, drops to a holding voltage of 70 Vdc. Circuitry includes surge suppression network to protect coil and minimize contact arcing. Complete circuit is housed in a NEMA 12 enclosure.

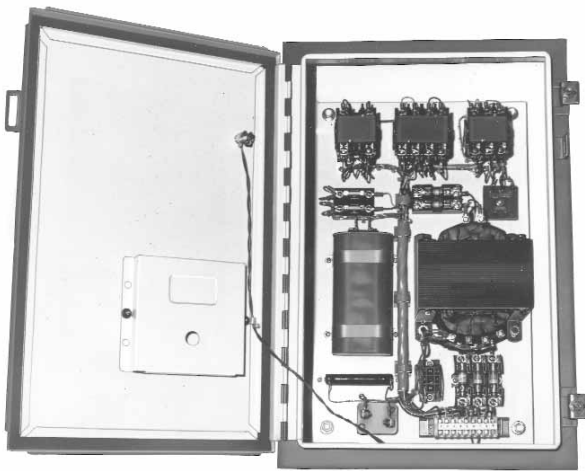

Dimensional Data

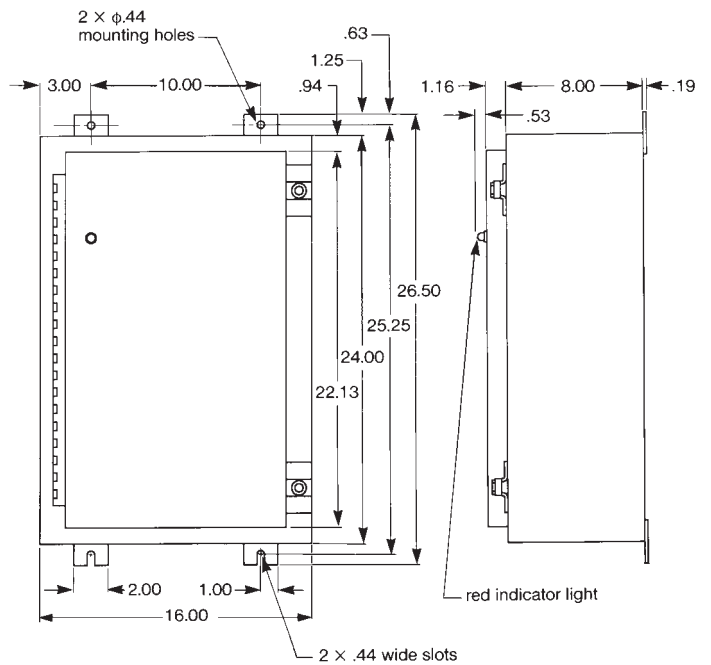

Wiring Diagram

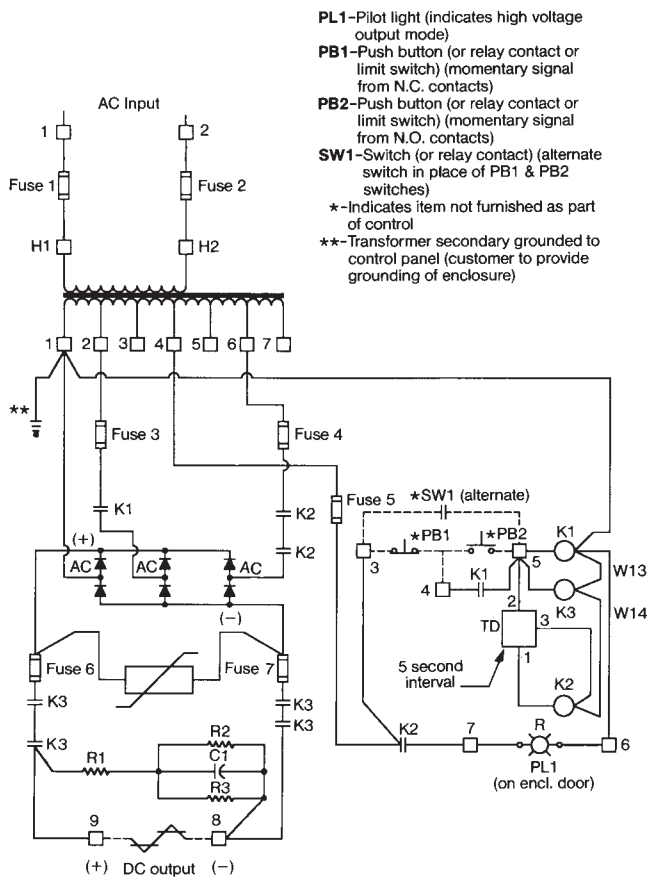

Performance Data

Stock Number	AC Input Voltage 50/60 Hz	DC Input			Approx. Shipping Wt. (lbs.)
		Forcing Volts	Holding Volts	Watts	
4-3-00115-12	115 Vac	230	70	1000	60
4-3-00208-12	208 Vac	230	70	1000	60
4-3-00230-12	230 Vac	230	70	1000	60
4-3-00460-12	460 Vac	230	70	1000	60
4-3-00575-12	575 Vac	230	70	1000	60

Application Engineering Data

Basic Torque Formula:

$$T = \frac{hp \times 5,252}{N_{cb}} \times SF$$

Where:

T = Average dynamic torque, lb-ft

hp = Motor horsepower

SF = Service factor

N_{cb} = rpm of the clutch/brake shaft

5,252 = Constant

Inertia:

$$I = W \times K^2$$

Where:

W = Weight of the object

K^2 = The square of the radius of gyration

Velocity, Linear:

$$V = \pi DN$$

Where:

$\pi = 3.142$

D = Diameter of drive head pulley

N = rpm

Reflected Inertia - Linear:

$$Wk_L^2 = W \left(\frac{V}{2\pi N_{cb}} \right)^2$$

Where

W = The weight of the component, lb

V = The velocity of the component in feet per minute

N_{cb} = The rpm of the clutch/brake shaft

Reflected Inertia - Rotational:

$$Wk_r^2 = Wk_C^2 \times \left(\frac{N}{N_{cb}} \right)^2$$

Where:

Wk_r^2 = Inertia reflected to the clutch or brake

Wk_C^2 = Inertia of the component

N = rpm of the component

N_{cb} = rpm of the clutch or brake shaft

Dynamic Torque:

$$T_d = \frac{Wk^2 \times N}{308 \times t}$$

Where:

T_d = Dynamic torque, lb-ft

Wk^2 = Total inertia seen by the clutch/brake (including the clutch/brake inertia and motor inertia if applicable), lb-ft²

N = rpm of the clutch/brake

t = Stopping time in seconds (or starting time)

308 = Constant

Thermal Capacity:

$$E = 1.7 \times WR^2 \left(\frac{N}{100} \right)^2 \times F$$

Where:

E = Energy (heat) which needs to be dissipated, (ft-lb/min) for the application requirement

WR^2 = Total reflected inertia at clutch/brake shaft location. This should include clutch/brake inertia. (lb-ft²)

N = Speed differential in revolutions per minute (rpm) at the clutch/brake shaft.

F = Number of cycles per minute (cycle rate).

Ohms Law:

Ohms = Volts/Amperes

$$\left(R = \frac{E}{I} \right)$$

Amperes = Volts/Ohms

$$\left(I = \frac{E}{R} \right)$$

Volts = Amperes \times Ohms
($E = IR$)

Power - DC Circuits:

Watts = Volts \times Amperes
($W = EI$)

$$\text{Amperes} = \frac{\text{Watts}}{\text{Volts}} \quad \left(I = \frac{W}{E} \right)$$

Inertia Table

Wk² of Steel Shafting or Disc per Inch of Length

Dia. (inch)	Wk ² (lb-ft ²)	Dia. (inch)	Wk ² (lb-ft ²)	Dia. (inch)	Wk ² (lb-ft ²)	Dia. (inch)	Wk ² (lb-ft ²)	Dia. (inch)	Wk ² (lb-ft ²)
1/8	4.53 × 10 ⁻⁸	4	.0491	9 3/4	1.735	25	75.00	48	1019.2
1/4	7.47 × 10 ⁻⁷	4 1/4	.0626	10	1.920	26	87.74	49	1106.8
3/8	3.83 × 10 ⁻⁶	4 1/2	.0787	10 1/2	2.334	27	102.0	50	1200.0
1/2	1.21 × 10 ⁻⁵	4 3/4	.0977	11	2.811	28	118.0	51	1298.9
5/8	2.93 × 10 ⁻⁵	5	.1200	11 1/2	3.358	29	135.8	52	1403.8
3/4	6.07 × 10 ⁻⁵	5 1/4	.1458	12	3.981	30	155.5	53	1514.9
7/8	.0001	5 1/2	.1757	12 1/2	4.687	31	177.3	54	1632.5
1	.0002	5 3/4	.2099	13	5.484	32	201.3	55	1756.9
1 1/8	.0003	6	.2488	13 1/2	6.377	33	227.7	56	1888.2
1 1/4	.0005	6 1/4	.2930	14	7.376	34	256.6	57	2026.7
1 3/8	.0007	6 1/2	.3427	14 1/2	8.487	35	288.1	58	2172.7
1 1/2	.0010	6 3/4	.3986	15	9.720	36	322.5	59	2326.5
1 5/8	.0013	7	.4610	15 1/2	11.08	37	359.8	60	2488.3
1 3/4	.0018	7 1/4	.5304	16	12.58	38	400.3	66	3643.1
1 7/8	.0024	7 1/2	.6075	16 1/2	14.23	39	444.2	72	5159.6
2	.0031	7 3/4	.6926	17	16.04	40	491.5	78	7166.7
2 1/4	.005	8	.7864	18	20.15	41	542.5	84	9558.9
2 1/2	.0075	8 1/4	.8894	19	25.02	42	597.4	90	12597
2 3/4	.0110	8 1/2	1.002	20	30.72	43	656.4	96	16307
3	.0156	8 3/4	1.125	21	37.34	44	719.6	102	20782
3 1/4	.0214	9	1.260	22	44.98	45	787.3		
3 1/2	.0288	9 1/4	1.405	23	53.73	46	859.6		
3 3/4	.0380	9 1/2	1.564	24	63.70	47	936.9		

To determine Wk² of a given shaft length or disc shape thickness, multiply the table value given above by the length, or thickness, in inches.

Material Factors

Multiply the inertia of the steel diameter by the selected material.	
Bronze 1.1	Nylon .18
Aluminum .35	Cast iron .92

Radius of Gyration, Squared

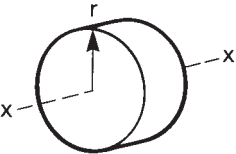
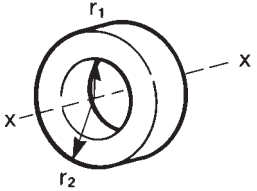
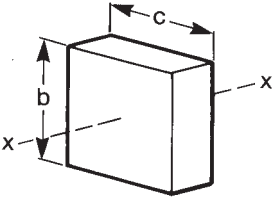
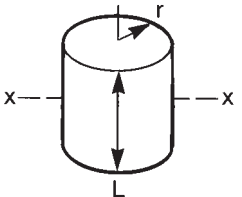
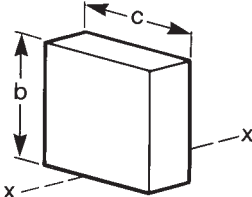
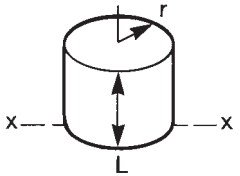
		Cylinder about Its Own Axis x-x			
	Solid $K^2 = 1/2 r^2$	Hollow $K^2 = 1/2 (r_1^2 + r_2^2)$			
		Axis through Center x-x			
	Prism $K^2 = 1/12 (b^2 + c^2)$	Cylinder $K^2 = \frac{L^2 + 3r^2}{12}$			
		Axis at One End x-x			
	Prism $K^2 = 1/12 (4b^2 + c^2)$	Cylinder $K^2 = \frac{4L^2 + 3r^2}{12}$			

English-Metric Conversion Factors

Multiply the base unit by the factor shown to obtain the desired conversion

Measurement	Base Unit	Factor	Conversion
Length	inch, in <i>millimeter, mm</i>	25.4 .03937	<i>millimeter, mm</i> inch, in
Torque	pound-inch, lb-in <i>newton-meter, Nm</i> pound-feet, lb-ft <i>newton-meter, Nm</i> ounce-inch, oz-in <i>newton-meter, Nm</i>	.112985 8.8507 1.355818 .73756 .007062 141.612	<i>newton-meter, Nm</i> pound-inch, lb-in <i>newton-meter, Nm</i> pound-feet, lb-ft <i>newton-meter, Nm</i> ounce-inch, oz-in
Moment of Inertia	pound-feet squared, lb-ft ² <i>kilogram-meter squared, kgm²</i>	.042 23.81	<i>kilogram-meter squared, kgm²</i> pound-feet squared, lb-ft ²
Kinetic energy	foot-pound, ft-lb <i>joule, J</i>	1.355818 .73756	<i>joule, J</i> foot-pound, ft-lb
Weight	pound, lb <i>kilogram, kg</i>	.453592 2.20462	<i>kilogram, kg</i> pound, lb
Horsepower (English)	horsepower, hp <i>kilowatt, Kw</i>	.7457 1.341	<i>kilowatt, kW</i> horsepower, hp
Thermal capacity	horsepower-seconds per minute, hp-sec/min	12.42833	<i>watts, W</i>
	<i>watts, W</i>	.08046	horsepower-seconds per minute hp-sec/min
Temperature	degrees Fahrenheit, °F <i>degrees Celcius, °C</i>	(°F - 32) × 5/9 (°C × 9/5) + 32	<i>degrees Celcius, °C</i> degrees Fahrenheit, °F

Conversion Factors for Thermal Capacity

Base Unit	Multiply by	To Obtain
horsepower	33,000	ft-lb/min
hp-sec/min	550	ft-lb/min
BTU/min	777.385	ft-lb/min
watts	44.254	ft-lb/min

Metric Bore and Keyways

Bore (millimeter) + .25 mm - .000 mm	Keyway (millimeter) Nominal
6	2 ξ 2
8	2 ξ 2
10	3 ξ 3
12	4 ξ 4
14	5 ξ 5
15	5 ξ 5
16	5 ξ 5
18	6 ξ 6
19	6 ξ 6
20	6 ξ 6
22	6 ξ 6
24	8 ξ 7
25	8 ξ 7
26	8 ξ 7
28	8 ξ 7
30	8 ξ 7

Contact factory for specific application information