

# SINPAC Switches: Brief Operating Description

For over 75 years, single-phase motors have utilized a mechanical centrifugal switch to switch the start circuit.

Inherent characteristics of a mechanical device have made these switches prone to various problems, including tolerances, tolerance build-ups, mechanical fatigue, vibration and a host of others that can lead to switch failures and/or performance inconsistency.

Our challenge was to design a reliable solid-state switch to replace the mechanical switch and actuator mechanism, and duplicate the function of connecting and disconnecting the start circuit at particular speeds with the additional benefits of a solid-state device. After considerable research, we decided a successful electronic motor starting switch could be created by sensing the voltages present in the main and start windings.

Until the rotor of a single-phase motor begins to rotate, there is no coupling between its start winding and main winding. When the rotor begins to turn, the main winding induces flux in the rotor, which then induces a voltage in the start winding. The voltage induced in the start winding is directly proportional to motor speed.

In Stearns SINPAC Electronic Switches, the voltage across a motor's main winding and the voltage across its start winding are sampled and fed to a comparator. The logic circuitry is designed so that the electronic switch interrupts the start circuit current after the motor has accelerated to the speed at which cut out voltage is developed, generally 75 to 80% of synchronous motor speed. The logic circuitry then shuts down the switch's power stage, which consists of a triac or inverse parallel SCR's. This function is referred to as "cut out." When the start circuit is disconnected, the main winding field then drives the motor's rotor to its running speed.

If the motor encounters an overload, and the motor speed falls to approximately 50% of its synchronous speed, the SINPAC Switch automatically reconnects the motor's start circuit. This function is referred to as "cut in." Cut in detection circuitry constantly monitors start winding voltage. When the motor's speed falls to the cut in point, the detection circuit causes the control logic to energize the SINPAC Switch's power output stage. The motor then goes through its normal startup procedure, with the start circuit being switched out at a motor

speed approximately 75 to 80% of synchronous speed.

SINPAC Switches are potted and completely sealed, making it impervious to dust, dirt and moisture. The unique speed sensing circuit provides a universal design which allows a few switches to work on most standard motor designs regardless of manufacturer.

## Acceptance by Motor Manufacturers

US and foreign motor manufacturers have tested and retested the SINPAC Switch for reliability and quality. Today, many of these manufacturers have begun installing SINPAC Switches on their standard motor lines with more companies ready to make the changeover.

## UL Recognition

Most SINPAC Switches have already been recognized under the Component Program of Underwriters Laboratories, Inc. (E-71115). In addition, all switches have internal surge protection which is tested according to ANSI/IEEE C62.41 – 1991 Category A3. CSA Certification LR-6254.

## Mounting Options

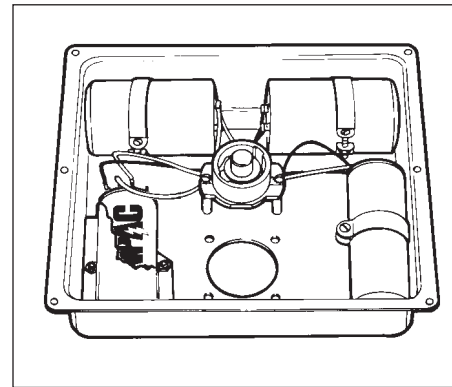
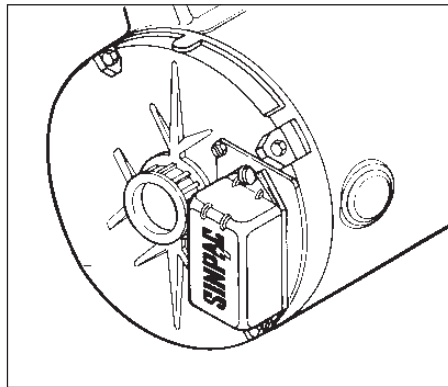
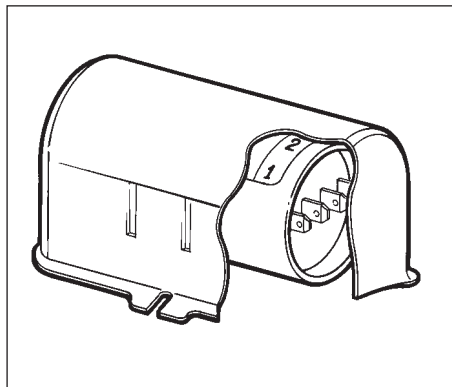
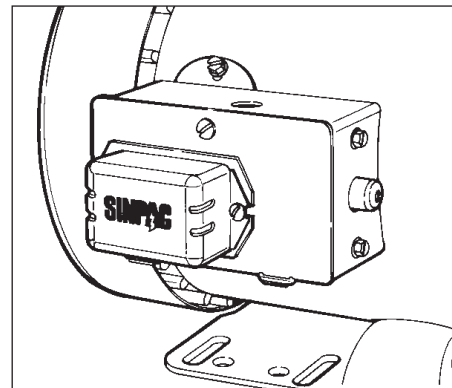
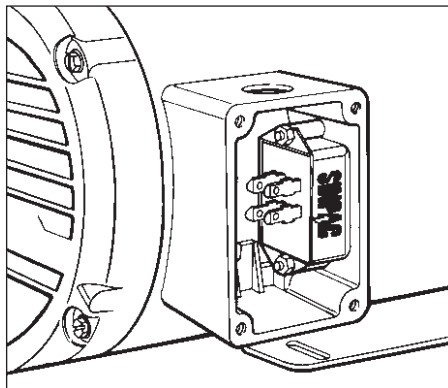
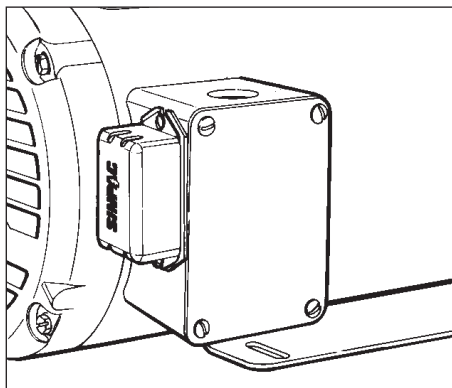

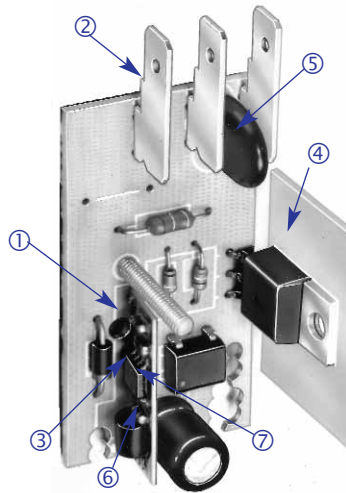

- ① **Electrically Protected.** Designed to filter out electrical noise, so there is no concern of random switch malfunction.
- ② **Reduced Installation Time.** Easy accessible 1/4 inch terminals and mounting, reduce the amount of time required to install SINPAC Switches or to change out mechanical switches.
- ③ **Restart Capability.** When motor speed drops below 50% of synchronous speed, the start winding is brought back into the circuit to reinitiate starting torque.
- ④ **Soldered Heat Sink.** High cycling.
- ⑤ **Transient Protection.** Transient protection tested per ANSI/IEEE C62.41 - 1991 Category A3.
- ⑥ **Universal Design.** 50/60 Hz operation. Will work on 2, 4 or 6 pole motors of any manufacturer. Reduced inventory.
- ⑦ **Line Voltage Compensation.** No modifications or changes are required for line voltage variations. SINPAC Switches will operate in areas susceptible to *brown-outs* or low voltage due to long wiring runs.

**ADDITIONAL FEATURES**

• **Operating Temperature:** -40°C to 65 °C (-40 °F to 149°F) [for operation between 65°C and 85°C (149°F and 185°F), consult factory.]

• **Operating Voltage:** 115 Vac SINPAC Switch: 90-130 Vac. For dual voltage motor equipped with center-tapped main winding: 90-130 Vac or 180-265 Vac. 230 Vac SINPAC Switch: 190-255 Vac.

## Typical Applications

Stearns SINPAC Switches are ideal for applications requiring reliable switching of the start circuit in single-phase motors.

Mechanical switches are prone to various problems including mechanical fatigue, tolerances, tolerance build-ups and vibration which can lead to performance inconsistency.

Electronic SINPAC Switches solve all those problems which reduce production downtime in hundreds of applications. Some of these applications are illustrated below:

**Some additional applications include:**

- Grain Dryers
- Water Equipment
- Power Tools
- Commercial Dryers
- Commercial Washing Machines
- Ice Makers
- Gas Pumps
- Floor Washers
- Bottle Washing Machines
- Floor Sanders
- Poultry Feeding Systems
- Fans, Blowers
- Grinding Machines
- Milking Machines
- Winches
- 50/60 Hz
- Paint Sprayers
- Pressure Sprayers
- Vibrators
- Auger Drives
- Door Openers
- Sump Pumps
- Diaphragm Pumps
- Hermetic Motors
- Rotary Compressors
- Refrigeration Compressors
- Heat Pumps
- Jet Pumps
- Food Processing

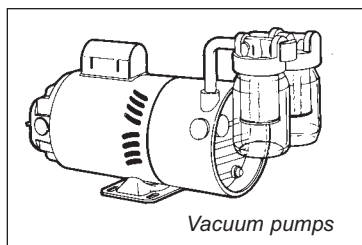
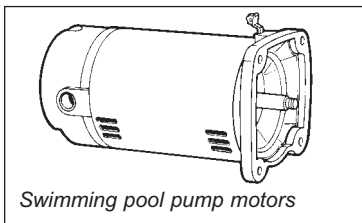
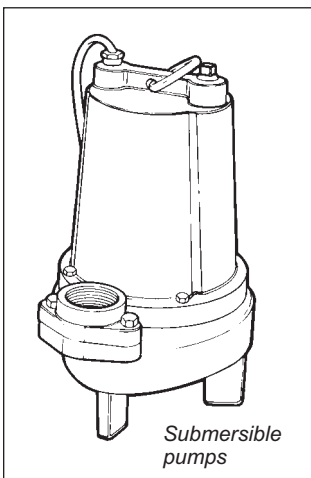
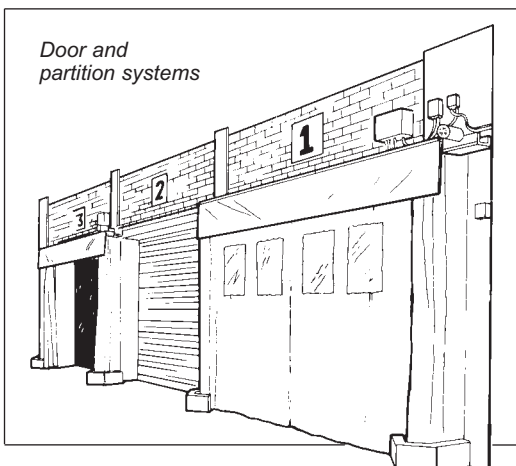
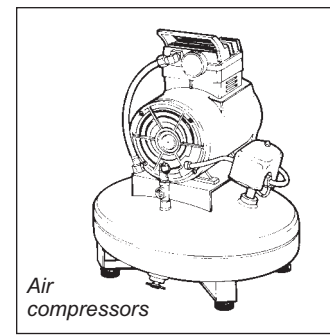
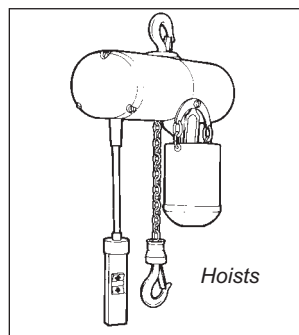
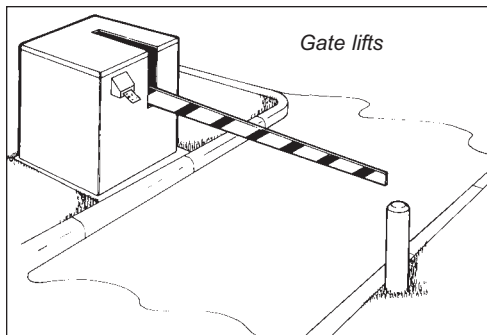

Motor hp ratings are typical. For an accurate selection procedure, measure start winding current during a normal start or at locked rotor and select a SINPAC Switch with higher maximum current rating than that measured.

1. Be sure switch series matches motor type.
2. Be sure switch voltage rating matches (start) circuit voltage rating.
3. Selection can be based on actual measurement of start winding current or two times the motor nameplate FLA rating.
4. Switch current rating must match or exceed the motor start winding current requirements. Always select a SINPAC Switch with the next higher current rating for:
  - a) High cycling applications.
  - b) Long acceleration time.
  - c) High ambients: Greater than 55°C.
5. To assure proper motor operation, the voltage across the start winding must reach the SINPAC Switch cut in reference voltage between 70% to 85% of motors synchronous speed.

**Caution:** SINPAC Switches are line voltage compensated. Changes in the line voltage will not effect system operation unless an overload condition causes reduced running speed, along with reduced voltage across the start winding.

6. Higher current switches can be used in place of lower rated switches of the same series.

## SINPAC Electronic Switch Catalog Numbering System

**CV - 16 - 165**

**Start Winding Voltage**  
*blank* = 115, **2** = 230

Cut Out Voltage (Cut In PV)

Maximum Current Rating

**Series**

**CVR** = Capacitor Start and Capacitor Start/Capacitor Run Motors, **PV** = Split Phase Only,

**CV** - Capacitor Start Only, **VR** = Capacitor Start/Capacitor Run Only, **IR** = Capacitor Start Instant Reverse

**4-7-21016-11-U01**

Electronics

7 = SINPAC Switch

1 = PV Series - Split Phase Only

2 = CV Series - Capacitor Start Only

3 = Made-To-Order (MTO)\*

4 = CVR Series - Capacitor Start and Capacitor Start/Capacitor Run

5 = IR Series - Capacitor Start Only

6 = Timer - Fixed Timer Split Phase or Capacitor Start

7 = VR Series - Capacitor Start/ Capacitor Run Only

1 = 115 Start Circuit Voltage

2 = 230 Start Circuit Voltage

0 = Standard

A = Inductor

**Amps (max. current)**

16, 25, 35, 40, 50, 70, or 80

1 = Standard, 2 = Standard, K = Kit

**115 V SINPAC Switch**

A = 130 VCO, B = 147 VCO, 0 = 165 VCO

0 = 400 mS Timing Interval, 30 V Cut In

D = 180 VCO

F = 400 mS Timing Interval, 10 V Cut In

J = 155 VCO Hybrid 6B

K = 165 VCO Hybrid 6

L = 130 VCO 15 VCI

P = 800 mS Timing Interval, 30 V Cut In

R = 115 VCO

T = 600 mS Timing Interval, 10 V Cut In

V = 210 VCO

W = 200 mS Timing Interval, 30 V Cut In

Y = 200 mS Timing Interval, 10 V Cut In

**230 V SINPAC Switch**

C = 260 VCO, 0 = 310 VCO, E = 410 VCO

H = 400 mS Timing Interval, 60 V Cut In

M = 340 VCO, S = 350 VCO

T = 600 mS Timing Interval, 60 V Cut In

U = UL Recognized, N = Not UL

**Package Style**

11 = Metal Can 2.48 x 1.38 x .81

12 = Metal Can 2.67 x 1.78 x .86

15 = Capacitor Case 1.822 dia. x 3.372 long

16 = Metal Can 2.75 x 2.0 x 1.125

17 = Capacitor Case 2.572 dia. x 4.372 long

19 = Capacitor Case 1.447 dia. x 3.372 long

20 = Capacitor Case 1.447 dia. x 2.760 long

21 = Board Only

\*NOTE: For part numbers beginning with 473 (these are OEM specials), the remaining digits of this numbering system do not apply.

# SINPAC Switches: Line Voltage Compensation Charts

## PV Series

Induced voltage across the start winding is directly proportional to motor speed and line voltage. All SINPAC Switches use this voltage to switch the start winding out of the circuit. Your motor with a SINPAC Switch must generate a voltage that is 20% greater than the switch cut in voltage to assure cut out of the start winding. Refer to the chart below.

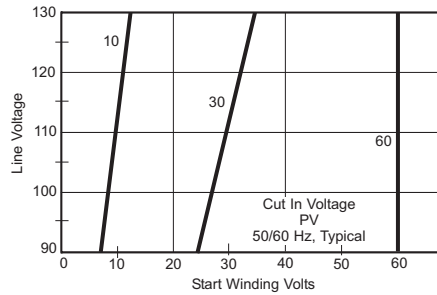

## CV , VR , CVR, and IR Series

Induced voltage across the start winding is directly proportional to motor speed and line voltage. All SINPAC Switches use this voltage to switch the start capacitor out of the circuit. Your motor with a SINPAC Switch must generate a voltage that is 20% greater than the switch cut out voltage to assure cut out of the start capacitor. Refer to charts below.

### CV and VR

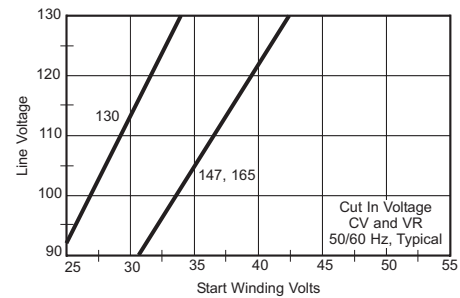
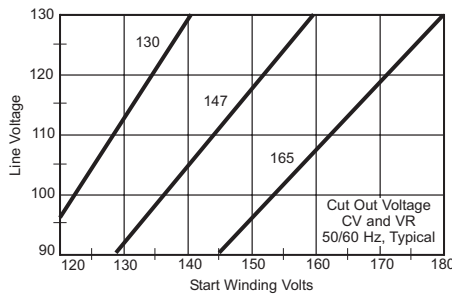

### CVR

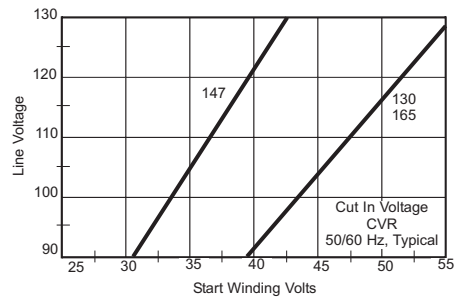
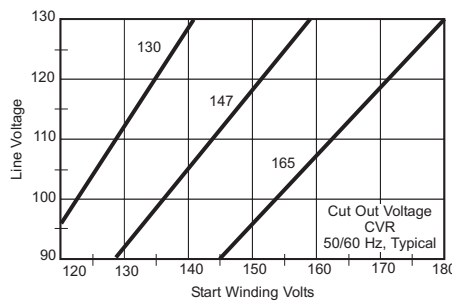

### 2CV , 2VR , and 2CVR

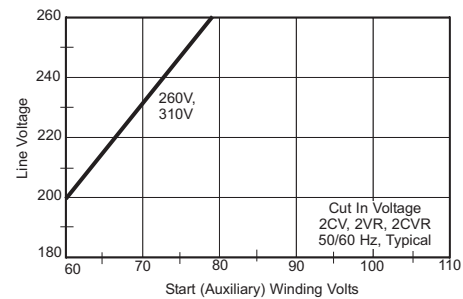
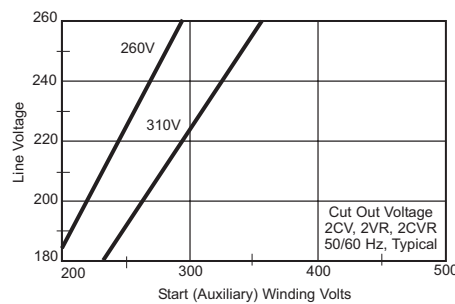

### IR SERIES

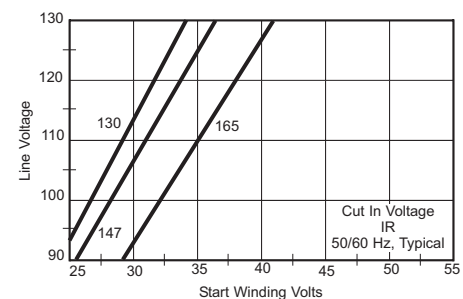
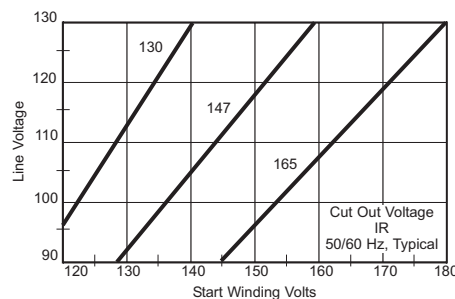

# VR Series for 115 Vac or 115/230 Vac Dual Voltage Capacitor Start/Capacitor Run Motors

BACK TO PAGE 1

## Basic Operation

Capacitor start/capacitor run motors provide continuous voltage sensing information which can be used to extract speed data from the voltage across the motor start winding. By comparing this start winding RPM-sensitive voltage to the main AC input voltage (which serves as a reference voltage), the switch determines when the start circuit should be de-energized. The electronic switch interrupts the start circuit current after the motor has accelerated to the cut out voltage (speed), and reconnects the start circuit whenever the speed sensitive circuit senses the motor voltage (speed) has decreased to a preselected cut in voltage (RPM) level.

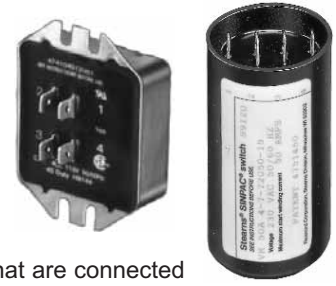

Capacitor start/capacitor run motors exhibit current transients and higher voltages across the start switch. These electrical stresses occur due to the switching of the two capacitors (start and run) that are connected in parallel during motor start and may have different voltages at time of restart. These stresses occur at restart with both mechanical and electronic start switches. The VR switch features circuitry designed to eliminate the effects of these conditions.

Typical Maximum Motor hp	Typical Full Load Motor Nameplate Current Rating (amps)		Switch Rating and Permissible Maximum Start Capacitor Current (amps)	Start Circuit Voltage	Catalog Number	Part Number	Cut Out Voltage Typical	Cut In Voltage Typical	Package Style
	115 Volts	115/230 Volts							
1/2	8	8/4	16	115	VR-16-130	4-7-71016-12-UA1	130	30	12
1/2	8	8/4	16	115	-	4-7-71016-19-UA1	130	30	19
1/2	8	8/4	16	115	VR-16-147	4-7-71016-12-UB1	147	37	12
1/2	8	8/4	16	115	-	4-7-71016-19-UB1	147	37	19
1/2	8	8/4	16	115	VR-16-165	4-7-71016-12-U01	165	37	12
1/2	8	8/4	16	115	-	4-7-71016-19-U01	165	37	19
2	20	20/10	40	115	VR-40-130	4-7-71040-12-UA1	130	30	12
2	20	20/10	40	115	-	4-7-71040-19-UA1	130	30	19
2	20	20/10	40	115	VR-40-147	4-7-71040-12-UB1	147	37	12
2	20	20/10	40	115	-	4-7-71040-19-UB1	147	37	19
2	20	20/10	40	115	VR-40-165	4-7-71040-12-U01	165	37	12
2	20	20/10	40	115	-	4-7-71040-19-U01	165	37	19
3	25	50/25	50	115	VR-50-130	4-7-71050-12-UA1	130	30	12
3	25	50/25	50	115	-	4-7-71050-19-UA1	130	30	19
3	25	50/25	50	115	VR-50-147	4-7-71050-12-UB1	147	37	12
3	25	50/25	50	115	-	4-7-71050-19-UB1	147	37	19
3	25	50/25	50	115	VR-50-165	4-7-71050-12-U01	165	37	12
3	25	50/25	50	115	-	4-7-71050-19-U01	165	37	19

## -19 Enclosure

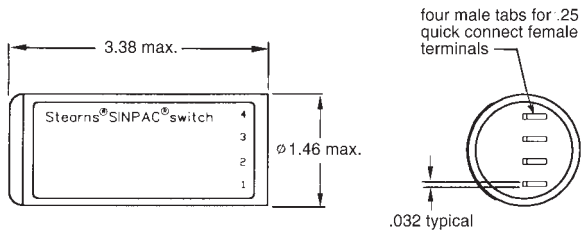

Dimensions are for estimating only. Drawings for customer reference are available upon request.

## -12 Enclosure

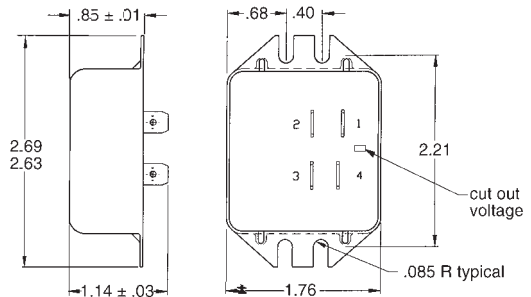

## Wiring Diagram

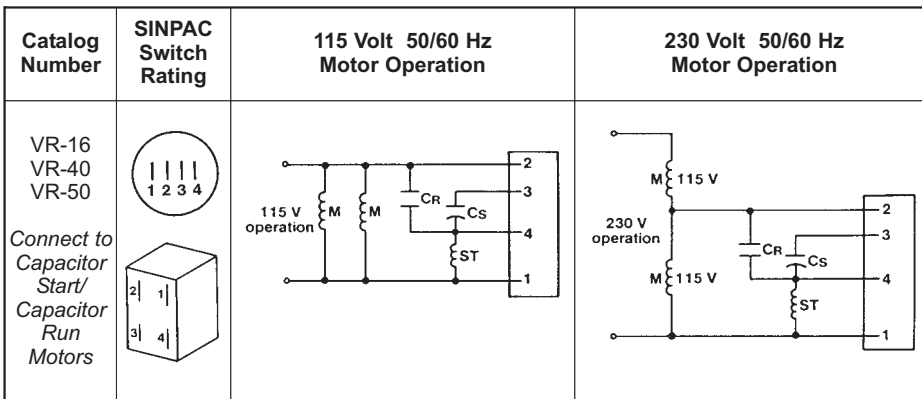

## Gasket

