

Series 320 Armature Actuated Brakes

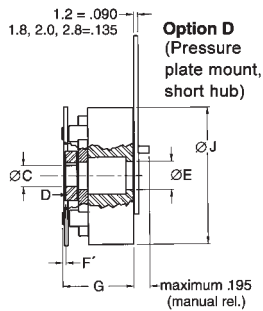

- Torque rating 3 to 50 lb-in / (.34 to 5.6 NM)
- UR and CUR Recognized insulation system, E-125303 and sizes 1.8, 2.8 brakes with internal power supply File E-71115
- Class B temperature rise with Class H mag wire
- Available with two types of friction disc for holding (H) or dynamic (D) stopping applications
- Corrosion resistance
- Optional Double D Friction disc-hub is not required, which reduces shaft machining, installation cost and assembly error.
- Optional maintained manual release
- Optional mounting plates to make conversion over to the superior Stearns product easy
- Optional AC Rectifiers - internal or external in-line
- Optional band seal (not available for 1.2 size)
- **Installation and Service Instructions:**
P/N 8-078-889-00

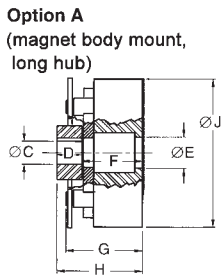
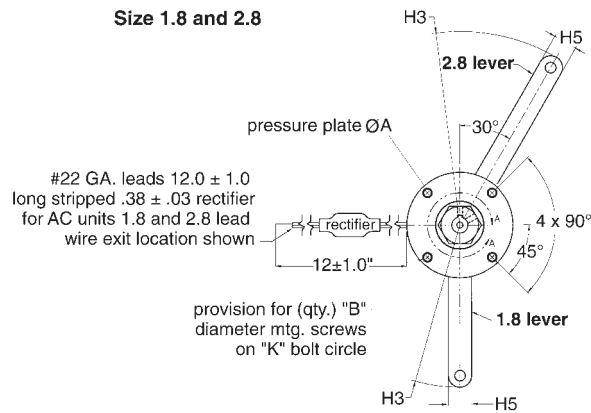
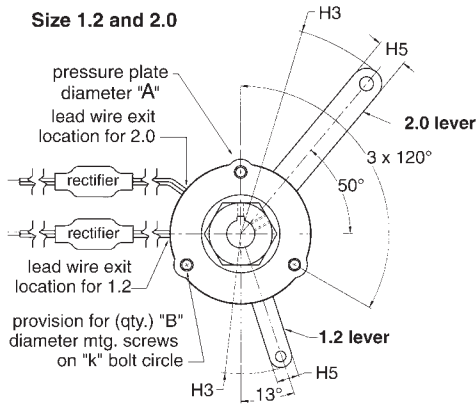

Double "D" Option

Brake Size	A	B	Shaft Size	C	D	E
1.2	.25 + .05/-00	.075 max.	5/16	.052	.105 / .103	.3135 / .3115
1.8	.30 + .13/-00	.075 max.	3/8	.063	.126 / .124	.376 / .374
2.0	.30 + .13/-00	.075 max.	1/2	.090	.181 / .179	.501 / .499

NOTE: Contact factory for Double "D" disc on brakes greater than 7 lb-in nominal static torque

Dimensional Data

Size	Model Number	Mounting Screw		Maximum Shaft Length (Manual Release Units)	Hub Location		E**	G	H Long Hub	H3	H5	J	D Hub Lengths		A
		Qty.	B		K	F							F'	Long	
1.2D 1.2H	3-20-2401G	3	Ø.140	Ø1.545	.300	(7.62)	.685	.890	1.065	2.5	.40	1.77	.38	.19	1.925
	#4, #6 (M3)		(39.243)	(17.40)			(22.60)	(27.05)	(9.65)						
1.8D 1.8H	3-20-4401G	4	Ø.177	Ø2.125	.430	(10.92)	.860	1.260	1.405	3.775	.55	2.43	.410	.25	2.55
	#8 (M4)		(53.975)	(21.84)			(32.00)	(35.69)	(10.16)						
2.0D 2.0H	3-20-5401G	3	Ø.145	Ø2.220	.430	(10.92)	.933	1.190	1.623	3.775	.55	2.50	.69	.31	2.50
	#6 (M3)		(56.388)	(23.70)			(13.46)	(30.23)	(95.885)						
2.8D 2.8H	3-20-7401G	4	Ø.188	Ø2.844	.490	(12.45)	.954	1.415	1.364	4.5	.55	3.25	.410	*	3.32
	#8 (M4)		(72.738)	(24.23)			(1.27)	(27.94)	(35.94)						

*Size 2.8 can be pressure plate mounted using the long hub. The F' dimension shown for size 2.8 is for pressure plate mount using the long hub.
** No thru bore with manual release option. For manual release with thru bore, see 321 & 322 Series on page 72.

Engineering Specifications/Pricing (Discount Symbol R2)

Size	Part Number	Nominal Static Torque		Friction Material	Approx Weight		Electric Power	Hub and Disc Inertia	Thermal Capacity	Maximum Bore	List Price Vdc		Options List Price Adders				
		lb-in	Nm		lbs	kg					(watts)	oz-in-sec ²	HP-sec/min	in	mm	Std Brake	With manual Release
1.2D	3-20-2401G-XX-XX	3	.34	Dynamic	.4	.181	7	7.02 x 10 ⁶	Consult Factory	3/8	9	\$90	\$115	No charge	Not available	\$40	N/A
1.2H ^①	3-20-2501G-XX-XX	5 ^①	.56	Holding ^①	.4	.181	9	7.02 x 10 ⁶		3/8	9	95	120	Not available	Not available	40	N/A
1.8D	3-20-4401G-XX-XX	7	.79	Dynamic	1.1	.499	10	4.8 x 10 ⁴	.26	1/2 ^②	12	100	130	No charge	\$10	40	\$8
1.8H ^①	3-20-4501G-XX-XX	15 ^①	1.69	Holding ^①	1.1	.499	10	4.8 x 10 ⁴		1/2 ^②	12	115	145	No charge ^③	10	40	8
1.8D	3-20-4601G-XX-XX	15	1.69	Dynamic	1.1	.499	10	4.8 x 10 ⁴		1/2 ^②	12	125	155	Not available	Not available	40	8
2.0D	3-20-5401G-XX-XX	18	2.03	Dynamic	1.2	.544	12.5	2.23 x 10 ³	.32	1/2	12	115	145	No charge ^③	10	40	8
2.0H ^①	3-20-5501G-XX-XX	30 ^①	3.39	Holding ^①	1.2	.544	12.5	2.23 x 10 ³		1/2	12	135	165	No charge ^③	10	40	8
2.8D	3-20-7401G-XX-XX	35	3.95	Dynamic	2.0	.91	17	2.3 x 10 ³	.17	1/2 ^②	12	155	185	Not available	10	40	11
2.8H ^①	3-20-7501G-XX-XX	50 ^①	5.65	Holding ^①	2.0	.91	17	2.3 x 10 ³		1/2 ^②	12	175	205	Not available	Not available	40	11

① For holding applications only. ② Set Screws located 120° from keyway. ③ Contact factory for Double "D" discs on brakes greater than 7 lb-in static torque

Ordering Information

Group "3" Armature Acting Brake. — 320-4401G-0H-JD — Options — Table 3

320 = For AAB-R Models

AAB-R Unit Sizes	Part Number
1.2	2
1.8	4
2.0	5
2.8	7

Voltages — Table 2

Hub bore and Keyway — Table 1
For Double "D" Bores See Table 1A

Character	Nominal Static Torque (lb-in)	List Adder
Size 1.2	4 3 Dynamic	---
	5 5 Holding	---
Size 1.8	4 7 Dynamic	---
	6 15 Dynamic	\$10.00
	9 9 Dynamic 5 15 Holding	\$ 5.00 ---
Size 2.0	4 18 Dynamic	---
	5 30 Holding	---
	3 15 Dynamic	---
	6 25 Holding 7 7 Dynamic	---
Size 2.8	4 35 Dynamic	---
	5 50 Holding	---

Characters to insert	Modification
E	Brake release indicator (NC)
F	Brake release indicator (NO)
G	Standard - GGA Friction Material
J	CCW manual release rotation
S	Carrier ring friction disc

Numeral or Letter	Options
1	Standard Unit
A-Z	Reserved for Mounting Plates

Numeral	Enclosure type
0	None
2	Band seal

Table 2: 320-44010-0H-[*]D
Standard Coil Voltage

Character to Insert	Voltage	List Adder*	Current Rating in Amps			
			Size 1.2	Size 1.8	Size 2.0	Size 2.8
C	12 Vdc	-	.632	.826	1.04	1.37
E	24 Vdc	-	.307	.421	.53	.70
G	48 Vdc	-	.158	.216	.27	.36
J	90 Vdc	-	.076	.123	.13	.17
K	103 Vdc	-	.085	.115	.121	.140
L	180 Vdc	-	.039	.060	.069	.09
N	115 Vac	\$25.00	.085	.115	.140	.140
P	230 Vac	\$25.00	.044	.059	.075	.097
Z	115/230 Vac	\$25.00	.085/.044	.115/.059	.140/.075	.140/.097

NOTE: Add \$20.00 for non-standard coil voltage
*For external in-line rectifier
(for internal rectifier, add \$15.00 list)

Table 1: 320-44010 - [*][*]-JD

Characters to insert	Bore	Keyway Size*		Bores Available			
		Width (in.) x Depth (in.)	Mag Body Size	1.2	1.8	2.0	2.8
0A	3/16	N/A	N/A	X			
0B	3/16	1/16	1/32		X		
0C	1/4	N/A	N/A	X			
0D	1/4	1/16	1/32		X	X	X
0E	5/16	N/A	N/A	X			
0F	5/16	1/16	1/32		X	X	X
0G	3/8	N/A	N/A	X			
0H	3/8	3/32	3/64		X	X	X
0J	1/2	1/8	1/16		①	①	①
05	5	2 mm	1 mm	②	X	X	X
06	6	2 mm	1 mm	②	X	X	X
07	7	2 mm	1 mm	②	X	X	X
08	8	2 mm	1 mm	②	X	X	X
09	9	3 mm	1.4 mm	②	X	X	X
10	10	3 mm	1.4 mm		X	X	X
11	11	4 mm	1.8 mm		X	X	X
12	12	4 mm	1.8 mm		X	X	X

NOTE: For non-standard bores add \$32.00.

- ① Set screws located 120° from keyway.
- ② Hubs are provided without keyway.
- *Keyseats made to ANSI B17.1 standard.

Table 1A: 320-44010 - [*][*]-JX
(Double "D" Bores)

Characters to insert	Bore	Bores Available	
		1.2	1.8/2.0
0F	5/16	X	X
0H	3/8	X	X

NOTE: Contact factory for Double "D" disc on brakes greater than 7 lb-in nominal dynamic torque. Can be used up to 15 lb-in for holding.

Table 3:
Options 320-44010-0H-J[*]

Characters	Options
A	Basic Brake, Magnet Body Mounted, Long Hub
D*	Basic Brake, Pressure Plate Mounted, Short Hub*
G*	Short Hub, Pressure Plate Mounted with Maintained Manual Release*
H	Long Hub with Maintained Manual Release, Size 2.8 Only
X	Double "D" Friction Disc
Y	Option X with Maintained Manual Release Pressure Plate Mounted

*Short hub not required for size 2.8 pressure plate mount.

NOTE: Final part number may change due to specifications or options selected or other product design considerations. A number such as a 2, 3, 4 etc., in the 12th position is used to designate a unique brake (custom) and can only be assigned by Stearns Design Engineering Department.

Modifications are available - see AAB Modification Section.

Armature Actuated Brakes (AAB) Torque Selection

Select the proper torque rating based on horsepower and rpm (speed at the clutch or brake) using the *Torque Selection Chart* below. Based on 1.4 service factor.

For other service factors and speeds, use the formulas shown below.

Formula for TABLE 1

$$T = \frac{63,025 \times P}{N} \times SF$$

T = Static torque, lb-in.
 P = Horsepower, hp
 N = Shaft speed at brake, rpm
 SF = Service Factor
 63,025 = Constant

Formula for TABLE 2

$$T = \frac{5,252 \times P}{N} \times SF$$

T = Static torque, lb-ft.
 P = Horsepower, hp
 N = Shaft speed at brake, rpm
 SF = Service Factor
 5,252 = Constant

Caution: Do not use Table 1 to select brakes for overhauling or high inertial loads, or where a stop in specified time or distance is required. For these applications the total inertia of the load and power transmission system must be determined to make a brake selection. Refer to sections on torque and thermal ratings and determination.

NOTE: Series 310 and 311 for holding applications only.

TABLE 1

Series 320, 321, 322 Static Torque in lb-in. (Nm)

Motor hp	rpm									
	600	800	1000	1200	1500	1800	2000	2400	3000	3600
	Static Torque lb-in (Nm)									
1/20	18 (.203)	7 (.79)	7 (.79)	7 (.79)	3 (.34)	3 (.34)	3 (.34)	3 (.34)	3 (.34)	3 (.34)
1/12	18 (.203)	18 (2.03)	7 (.79)	7 (.79)	7 (.79)	7 (.79)	7 (.79)	3 (.34)	3 (.34)	3 (.34)
1/8	35 (3.95)	18 (2.03)	18 (2.03)	18 (2.03)	18 (2.03)	7 (.79)	7 (.79)	7 (.79)	7 (.79)	3 (.34)
1/6	35 (3.95)	35 (3.95)	18 (2.03)	18 (2.03)	18 (2.03)	18 (2.03)	18 (2.03)	7 (.79)	7 (.79)	7 (.79)
1/4	—	35 (3.95)	35 (3.95)	35 (3.95)	18 (2.03)	18 (2.03)	18 (2.03)	18 (2.03)	18 (2.03)	7 (.79)
1/3	—	—	35 (3.95)	35 (3.95)	35 (3.95)	18 (2.03)	18 (2.03)	18 (2.03)	18 (2.03)	18 (2.03)
1/2	—	—	—	—	35 (3.95)	35 (3.95)	35 (3.95)	35 (3.95)	18 (2.03)	18 (2.03)
3/4	—	—	—	—	—	—	35 (3.95)	35 (3.95)	35 (3.95)	35 (3.95)
1	—	—	—	—	—	—	—	—	—	35 (3.95)

TABLE 2

Series 333/350/360 Static Torque in lb-ft. (Nm)

Motor hp (kw)	rpm									
	600	800	1000	1200	1500	1800	2000	2400	3000	3600
	Static Torque lb-ft (Nm)									
1/3 (.25)	6 (8)	6 (8)	3 (4)	3 (4)	3 (4)	3 (4)	3 (4)	3 (4)	3 (4)	3 (4)
1/2 (.37)	12 (16)	6 (8)	6 (8)	6 (8)	3 (4)	3 (4)	3 (4)	3 (4)	3 (4)	3 (4)
3/4 (.55)	12 (16)	12 (16)	6 (8)	6 (8)	6 (8)	6 (8)	3 (4)	3 (4)	3 (4)	3 (4)
1 (.75)	25 (34)	12 (16)	12 (16)	12 (16)	6 (8)	6 (8)	6 (8)	6 (8)	6 (8)	3 (4)
1-1/2 (1.1)	25 (34)	25 (34)	12 (16)	12 (16)	12 (16)	12 (16)	6 (8)	6 (8)	6 (8)	6 (8)
2 (1.5)	25 (34)	25 (34)	25 (34)	25 (34)	12 (16)	12 (16)	12 (16)	6 (8)	6 (8)	6 (8)
3 (2.2)	45 (60)	45 (60)	25 (34)	25 (34)	25 (34)	25 (34)	12 (16)	12 (16)	12 (16)	12 (16)
5 (3.7)	60 (80)	60 (80)	45 (60)	45 (60)	25 (34)	25 (34)	25 (34)	25 (34)	25 (34)	12 (16)
7-1/2 (5.6)	110 (150)	110 (150)	60 (80)	60 (60)	45 (60)	45 (60)	45 (60)	25 (34)	25 (34)	25 (34)
10 (7.5)	180 (240)	110 (150)	110 (150)	110 (150)	60 (80)	45 (60)	45 (60)	45 (60)	25 (34)	25 (34)
15 (11.2)	300 (400)	180 (240)	110 (150)	110 (150)	110 (150)	60 (80)	60 (80)	60 (80)	45 (60)	45 (60)
20 (14.9)	300 (400)	180 (240)	180 (240)	180 (240)	110 (150)	110 (150)	110 (150)	60 (80)	60 (80)	60 (80)
25 (18.6)	—	300 (400)	180 (240)	180 (240)	180 (240)	110 (150)	*	*	*	*
30 (22.4)	—	300 (400)	300 (400)	300 (400)	180 (240)	180 (240)	*	*	*	*
40 (29.8)	—	—	300 (400)	300 (400)	300 (400)	180 (240)	*	*	*	*
50 (37.3)	—	—	—	—	300 (400)	300 (400)	*	*	*	*
60 (44.7)	—	—	—	—	300 (400)	300 (400)	*	*	*	*

* Exceeds maximum speed rating.

Installation and Service Instructions for 320 Series AAB Spring-Set Brakes

Important

Please read these instructions carefully before installing, operating, or servicing your Stearns brake. Failure to comply with these instructions could cause injury to personnel and/or damage to property if the brake is installed or operated incorrectly. For definition of limited warranty/liability, contact Rexnord Industries, LLC., Stearns Division, 5150 S. International Dr., Cudahy, Wisconsin 53110, (414) 272-1100.

OEM's and subsystem suppliers, please forward these instructions with your components to the final user.

Caution

1. Servicing shall be in compliance with applicable local safety codes including Occupational Safety and Health Act (OSHA). All wiring and electrical connections must comply with the National Electric Code (NEC) and local electric codes in effect.
2. To prevent an electrical hazard, disconnect power source before working on the brake. If power disconnect point is out of sight, lock disconnect in the off position and tag to prevent accidental application of power to system.
3. To avoid damage to internal power supply, hipot testing should not exceed 1500 volts for one second. Brake coil leads must be connected together.
4. Heat developed during normal operation (135°C) of the brake may be hot enough to be painful or cause injury. Be careful when touching exterior surfaces. Allow sufficient time for the brake to cool before servicing.
5. After usage, the brake will contain burnt and degraded friction material dust. This dust should be removed before servicing or adjusting the brake.

DO NOT blow off dust using an air hose. It is important to avoid dispersing dust into the air or inhaling it, as this may be dangerous to your health.

- a) Wear a filtered mask or a respirator while removing dust.
- b) Use a vacuum cleaner or a soft brush to remove dust from the brake. When brushing, avoid causing the dust to become airborne. Collect the dust in a container, such as a bag, which can be sealed off.

Installation

The brake can be mounted on either face. With units mounting on the hub end, the hub should be secured to shaft before mounting brake. Two set screws are provided and should be tightened securely. Refer to Table A for set screw torque. The key should not extend towards the armature or past the face of the hub. Refer to Table B or C for positioning of hub. Mount brake to register using

screws or bolts. Refer to Table A for mounting torque. Lock washers are optional. The rated voltage should be available at the brake and allowance should be made for voltage drop in long wiring runs. The optional, factory installed, manual release lever is a rotary maintained design.

Note: Position of hub should allow full engagement of friction disc without interfering with the movement of the armature. Motor shaft end float should be taken into consideration when positioning the hub.

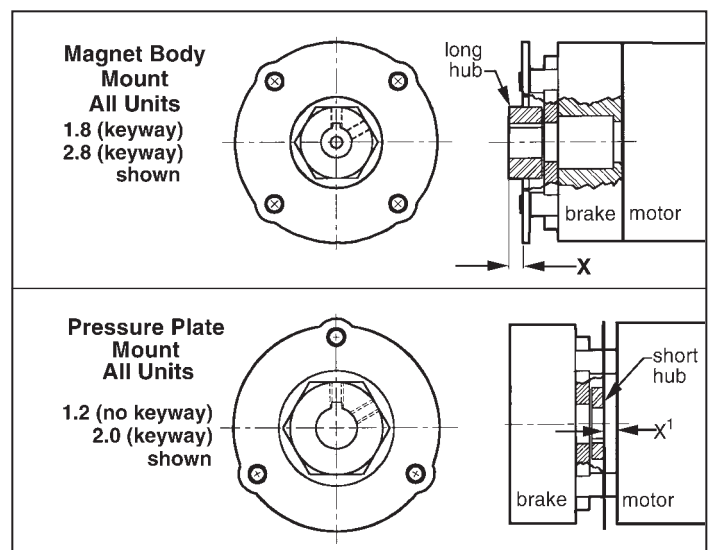

Table A

Set Screw Torque			Mounting Screws		
AAB Size	Short Hub	Long Hub	Size	Max Torque	Min Req
1.2	9-10 lb-in	9-10 lb-in	#6	20 lb-in	3
1.8	9-10 lb-in	18-20 lb-in	#8	37 lb-in	2
2.0*	9-10 lb-in	18-20 lb-in	#6	20 lb-in	3
2.8	9-10 lb-in	18-20 lb-in	#8	37 lb-in	2

*An adapter plate is available for mounting on motors with four equally spaced holes on a 2.844 inch bolt circle.

Table B

Size	Hub Position (inch)		Operating Range Air Gap (inches)	Maximum Allowed Misalignment (inches)	
	X	X ¹		Parallel	Angular
1.2	.21	.015*	.003 to .012	.005	.005
1.8	.17	.015*	.003 to .015	.005	.005
2.0	.49	.015*	.003 to .015	.005	.005
2.8	See back page				

*This dimension is for units mounting on hub end, and using short version of the hub. Factor in motor shaft end float; do not allow hub to contact armature.

Pressure Plate Mount
Size 2.8

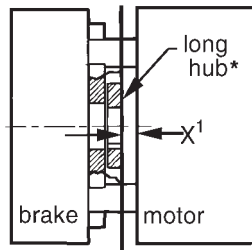

Magnet Body Mount
Size 2.8

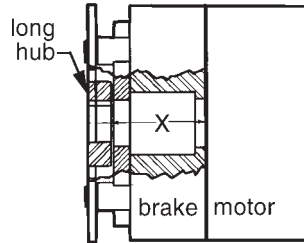

*Size 2.8 can be pressure plate mounted using the long hub.

Size	Hub Position (inch)		Operating Range Air Gap (inches)	Maximum Allowed Misalignment (inches)	
	X	X ¹		Parallel	Angular
2.8	.954	.050	.003 to .015	.005	.005

Repairs

The hub is the only replaceable item in this brake.

General

After proper installation, no further adjustment should be required for the life of the unit.

Full rated torque of a new AAB brake may not develop until the mating surfaces have been burnished or *run-in*.

Power supply

The voltage to be applied is determined by rating shown on the nameplate. Resistance and other coil data for various voltages are tabulated on appropriate Engineering Data Sheets. This data can be secured by contacting the factory.

Troubleshooting for AAB Brakes

Overheating, coil burned out or loss of torque

1. Check ambient temperature. It is above 40° C? Consult factory for assistance.
2. Check thermal capacity of unit versus actual heat dissipation requirements. Consult factory.
3. Check voltage supply as close to coil as feasible. Compare to nameplate data, if incorrect apply proper voltage.
4. Is coil resistance correct? Consult factory for resistance of the specific coil.

Caution: To avoid damage to power supply, hipot testing should not exceed 1500 volts for one second. Brake coil leads must be connected together.

5. Stop time on brake normally should not exceed one second. If excessive, recheck torque rating versus load characteristics.
6. Check for oil/grease on friction elements. If this is found, replacement of entire brake may be required.
7. On pressure spring, check for broken, missing or substituted springs not of our design.
8. Failure to release after unit has performed satisfactorily for a period indicates wear has occurred. Replacement of the brake is required.

Fuse in DC power supply blows









1. Never put in a higher rating fuse or replace with a slo-blow type.
2. Check resistance of coil, if shorted, replacement of brake is required. If not shorted, obtain coil resistance from factory and compare to your reading.
3. If cause was not found in Step 2 above, check rectifier bridge by removing all loads and replacing fuse. If fuse blows when AC is applied to rectifier, bridge is shorted. Replace bridge if feasible or discard control and replace.



Armature Actuated Brake Modifications

[BACK TO PRODUCT PAGE](#)

Series 320/321/322

Modification	Series	Brake Size	List Price
Maintained Manual Release			
	320/321/322	1.2 1.8 2.0 2.8	\$25.00 \$30.00 \$30.00 \$30.00
Non-Maintained Manual Release			
	320/321/322	1.2 1.8 2.0 2.8	\$25.00 \$30.00 \$30.00 \$30.00
Brake Release Indicator Switch			
	320/321/322	ALL	\$40.00
AC Rectifiers, In-Line			
	310/320/321/322	ALL	\$25.00
AC Rectifiers, Internal	320/321/322	1.8 and 2.8	\$15.00
Encoder Mount			
	310/320/321/322 tapped holes in magnet body for tether mount		\$25.00
Through-Shaft			
	321/322	ALL (through-shaft combined with manual release only available on size 2.8)	\$5.00
Mounting Plates			
	320/321/322	Size	List Price
		1.2	\$20.00
		1.8, 2.8	\$15.00
		1.8, 2.8 3.5", 2.5" register	\$30.00
		2.0 2.844"	\$20.00
Double "D" Disc			
	320/321/322	1.2, 1.8, and 2.0 Contact factory for Double "D" disc on brakes rated greater than 7 lb-in	No charge
Carrier Ring Disc	320/321/322	1.8	\$10.00