



ELECTRIC MOTORS  
GEARMOTORS AND DRIVES

P/N 8-078-935-14  
effective 7/20/05

# Installation and Service Instructions for Stock No. 1-056-7XX-08 (7/8" OD x 5/8" ID Sleeve)

## Addendum to Sheet 8-078-905-68, Installation, Service & Parts List for Series 56,700 Double C-face Coupler

For NEMA 56C motors, install sleeve  
on motor shaft.

For NEMA 143TC and 145TC gear  
reducers, install sleeve on brake  
output shaft.

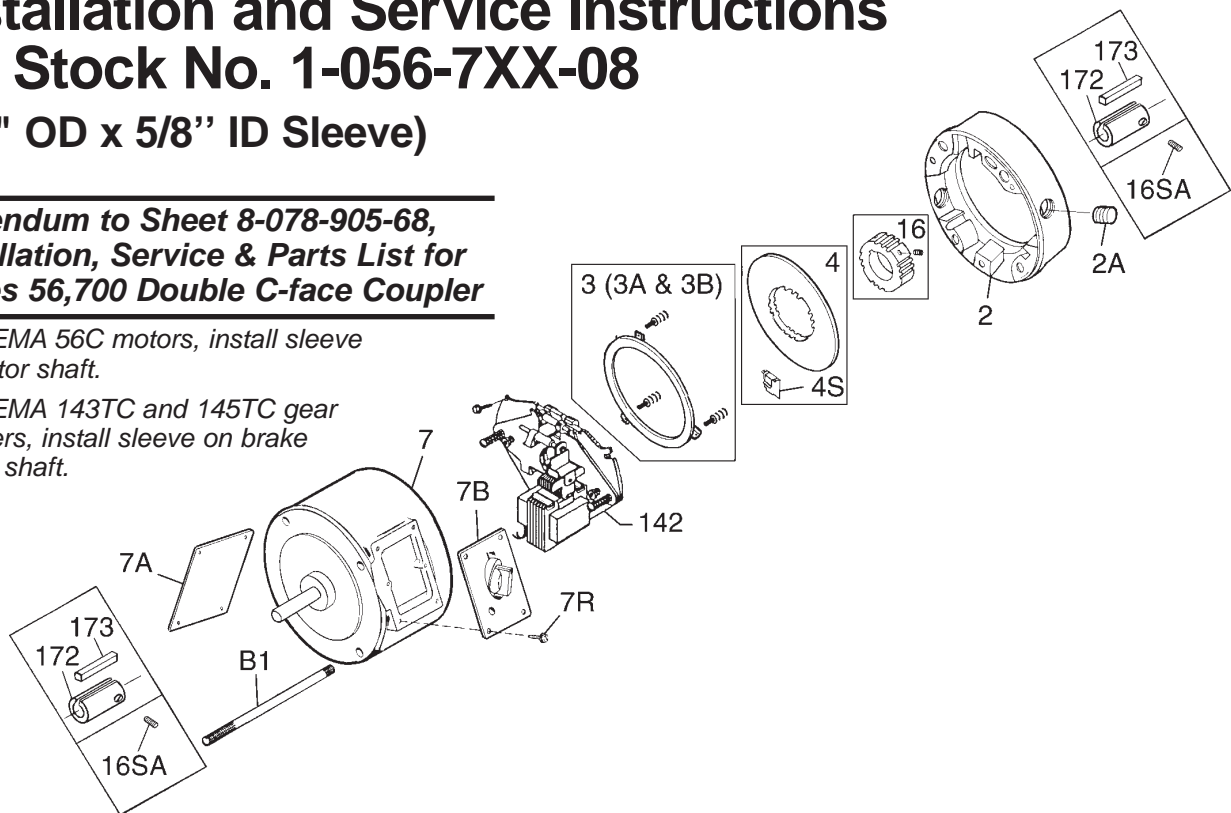

### Important

1. Please read these instructions carefully before installing, operating, or servicing your Stearns Brake. Failure to comply with these instructions could cause injury to personnel or damage to property if the brake is installed or operated incorrectly. For definition of limited warranty/liability, contact Rexnord Industries, Inc., Stearns Division, 5150 S. International Dr., Cudahy, Wisconsin 53110, (414) 272-1100.
2. This addendum is used in conjunction with Sheet 8-078-905-68; please follow all cautions and warnings noted on that instruction sheet.

### Installation procedure for sleeve (172) on motor shaft

**Note:** Follow *Brake Mounting Procedure*, Steps 4 through 8 on Sheet 8-078-905-68 (Installation, Service & Parts List for Series 56,700 Double C-face Coupler), after completing steps 2 through 5 below.

1. Slide sleeve (172) and rectangular key (173) onto motor shaft to approximately 3/16" from the motor mounting face.
2. Remove the hub (16) set screw that is 90° from the keyway. Replace with 1/2" long set screw (16SA).
3. Slide the hub onto the sleeve with the rectangular key in place. The 1/2" long set screw (16SA) must be placed over the clearance hole of the bushing. A dimple drilled into shaft for set screw at 90° from keyway is recommended to preclude hub shift on certain applications especially vertical.

4. With the hub within 3/16" of the motor mounting face and the key flush with the hub face, securely tighten both set screws to 156 in-lb torque, or until the long arm of hex wrench flexes.
5. Follow *Installation Procedure*, Steps 5 through 8 on Sheet 8-078-905-68.

### Installation procedure for sleeve (172) on brake output shaft for 7/8" bore accessory drive member

**Note:** Follow *Installation Procedure*, Steps 1 through 8 on Sheet 8-078-905-68.

1. Slide the sleeve (172) and rectangular key (173) onto the brake output shaft (35). The key and the sleeve shall be flush with the output shaft end.
2. Slide the accessory drive member onto the sleeve with the rectangular key in place. Remove the accessory's set screw that is 90° from the keyway. Replace with 1/2" long set screw (16SA). The 1/2" long set screw must be placed into the clearance hole of the bushing. To prevent shift of accessory drive member, a dimple may be drilled into shaft at set screw (16SA) position on certain applications, especially vertical.

**Note:** In the case of installation into a hollow shaft gear reducer, set screw retention, Steps 2 and 3 are not required.

3. With the accessory in position, securely tighten both set screws to 156 in-lbs torque, or until the long arm of hex wrench flexes.