

ELECTRIC MOTORS  
GEARMOTORS AND DRIVES

# Installation and Service Instructions for 56/143-5TC Double C-Face Coupler (Rev C)

For replacement parts refer to sheet part number 8-078-906-07. Instructions and parts list also available at [www.stearns.rexnord.com](http://www.stearns.rexnord.com).

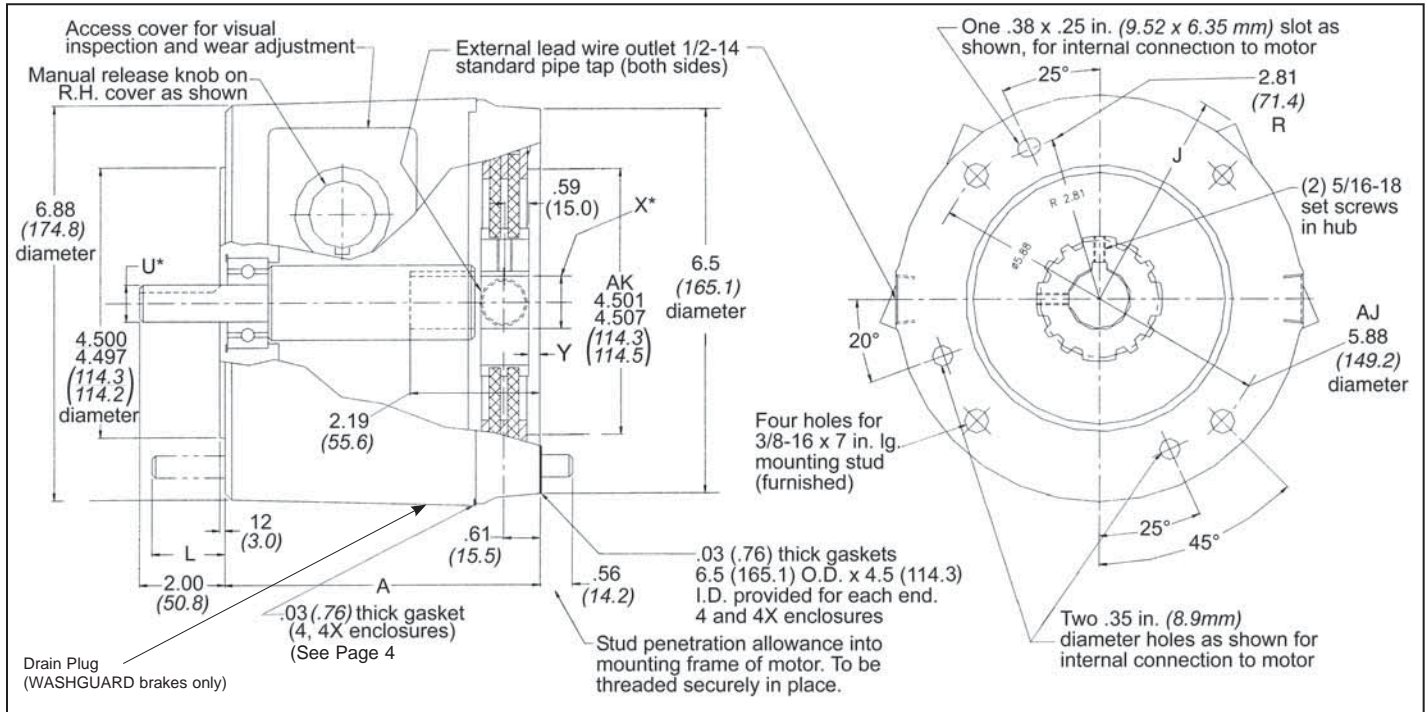

Figure 1 Position hub to Y as shown:  
Y=.32" (8.1mm) for 1 & 2 disc (1.5 - 15 lb-ft)  
Y=.19" (4.8mm) for 3 disc (20 & 25 lb-ft)

### Tools required for installation and servicing:

|                  |                  |                      |               |
|------------------|------------------|----------------------|---------------|
| 3/8" hex wrench  | 5/16" nut driver | 5/16" hex wrench     | Torque wrench |
| 1/4" screwdriver | 3/16" hex wrench | 8" adjustable wrench |               |

### Important

Please read these instructions carefully before installing, operating, or servicing your brake. Failure to comply with these instructions could cause injury to personnel and/or damage to property if the brake is installed or operated incorrectly. For definition of limited warranty/liability, contact Leeson Electric Corporation, P.O. Box 241, 2100 Washington Street, Grafton, WI 53024-0241, (262) 377-8810.

### Caution

- Installation and servicing must be made in compliance with all local safety codes including Occupational Safety and Health Act (OSHA). All wiring and electrical connections must comply with the National Electric Code (NEC) and local electric codes in effect.
- Do not operate the brake in atmospheres containing explosive gases or dusts.
- To prevent an electrical hazard, disconnect power source before working on the brake. If power disconnect point is out of sight, lock disconnect in the off position and tag to prevent accidental application of power.

- Make certain power source conforms to the requirements specified on the brake nameplate.
- Be careful when touching the exterior of an operating brake. Allow sufficient time for brake to cool before disassembly. Surfaces may be hot enough to be painful or cause injury.
- Do not operate brake with housing removed. All moving parts should be guarded.
- Installation and servicing should be performed only by qualified personnel familiar with the construction and operation of the brake.
- For proper performance and operation, only genuine Stearns parts should be used for repairs and replacements.
- After usage, the brake interior will contain burnt and degraded friction material dust. This dust must be removed before servicing or adjusting the brake.

DO NOT BLOW OFF DUST using an air hose. It is important to avoid dispersing dust into the air or inhaling it, as this may be dangerous to your health.

a) Wear a filtered mask or a respirator while removing dust from the inside of a brake.

b) Use a vacuum cleaner or a soft brush to remove dust from the brake. When brushing, avoid causing the dust to become airborne. Collect the dust in a container, such as a bag, which can be sealed off.

- Caution!** While the brake is equipped with a manual release to allow manual shaft rotation, the motor should not be run with the manual release engaged, to avoid overheating the friction disc(s).

**Warning!** Do not apply overhung or side load to brake output shaft

### General Description

The 56,700 Series coupler is a spring-set, electrically released brake, containing either one or more rotating friction discs (4) driven by a hub (16) mounted on the motor shaft. The double C-face allows the brake to directly couple a C-face motor to a C-face gear reducer.

## BRAKE MOUNTING (Manual Adjust)

**1** Place hub on motor shaft.

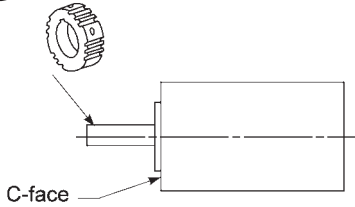

**2** Position hub to Y as shown:  
Y=.32" (8.1mm) for 1 & 2 disc (1.5 - 15 lb-ft)

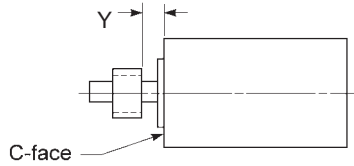

**3** Tighten set screws to motor shaft.

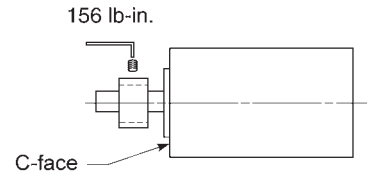

**4** A. Remove housing nuts and slide tie bolt out of brake.  
B. Remove housing from endplate.

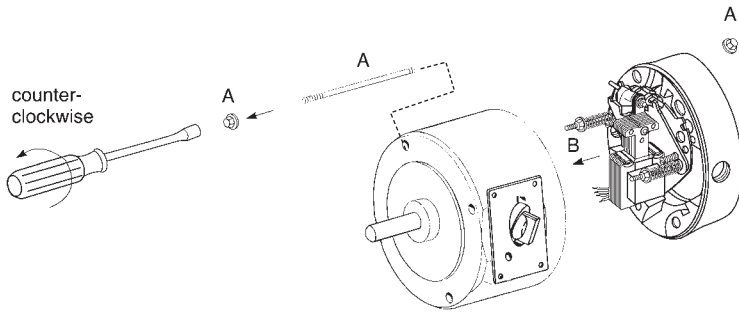

**5** Slide endplate over hub noting position of stabilizer clips, if used. (Refer to Friction Disc Replacement view 3 and 3A). Mount brake endplate to motor C-face using the four tie bolts. Insert minimum 4 turns.

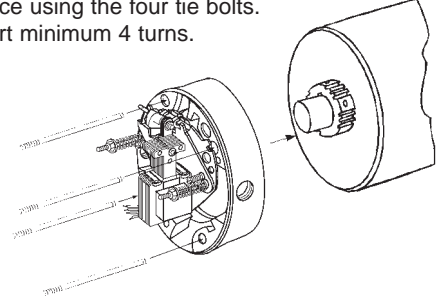

**6** Connect coil lead-wires to power supply. Refer to nameplate for voltage rating.\*  
**Caution:** Keep wiring away from pinch points and moving components.

### Coil Wiring

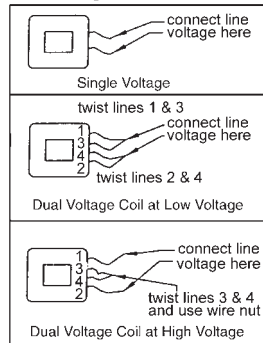

**7** A. Slide housing and shaft assembly onto mounting studs, rotating shaft until keyway is aligned. Be sure housing is assembled with access windows in same position as shown in Figure 1, page 1.

B. Mount and secure brake/motor assembly to C-face mounting register of reducer. Using four 3/8 - 16 nuts and lockwashers, tighten to 30-35 ft-lb.

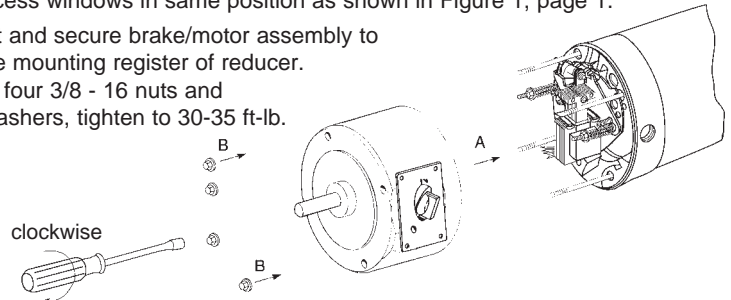

## FRICTION DISC REPLACEMENT SERIES

**1** Remove support plate screws and lift support from brake

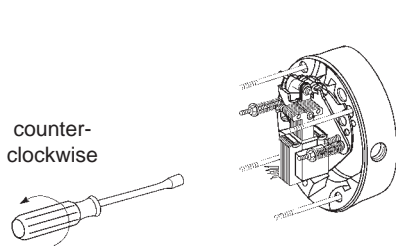

**2** Remove and discard old friction disc.

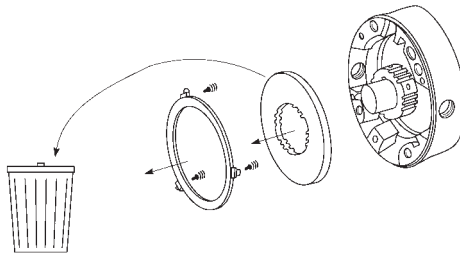

**3** Install new friction disc(s) and stationary disc(s) as shown.

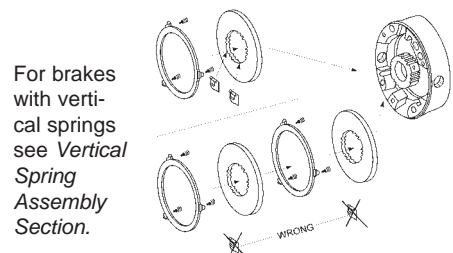

**3A**

\* Stabilizer clips are for use on single disc units only. Position clips opposite set screw holes.

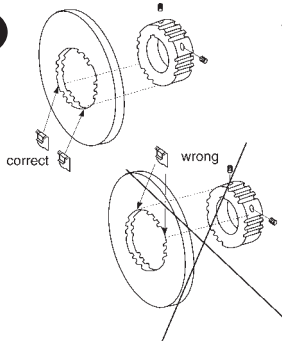

**4** Reposition support plate on endplate and tighten mounting screws to 55 lb-in.

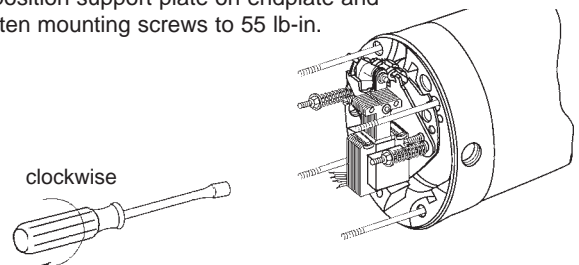

**Note:** Friction discs can wear to 1/2 their original thickness, or .093"

## AIR GAP ADJUSTMENT

As friction disc wear the air gap will increase. When plunger gets to the reset position, the air gap must be adjusted.

- 1** To **increase** air gap, turn both adjusting screws (10) counterclockwise.

56,X00 Series Air Gap\*

| Disc | Torque  | Min/Max     |
|------|---------|-------------|
| 1    | 3 & 6   | .38" ± .69" |
| 2    | 10 & 15 | .45" ± .69" |

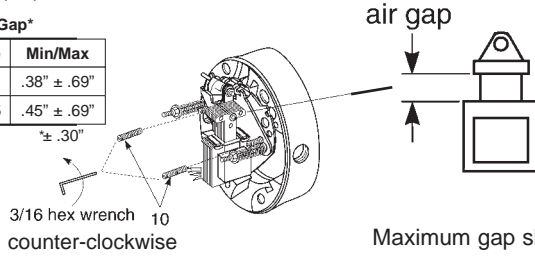

- 2** To **decrease** air gap, turn both adjusting screws (10) clockwise.

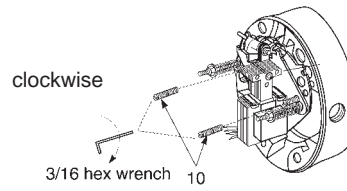

**Note:** Air gap can be adjusted without disassembly. Remove plate (7A) and manual release plate (7B) and adjust as shown above.

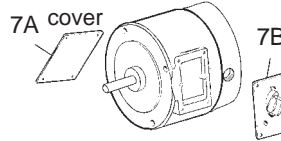

## COIL REPLACEMENT SERIES

Remove housing and disconnect power and wiring to coil.

- 1** Insert screwdriver between support plate and lever arm and pry forward.

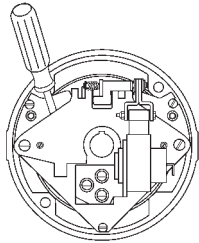

- 2** Lift plunger/solenoid lever assembly out of coil.

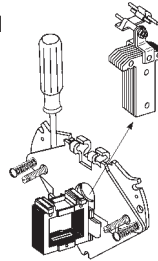

- 3** Remove plunger guide.

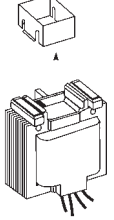

- 4** Discard coil.

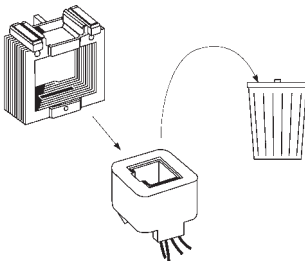

- 5**  
A) Insert new coil.  
(Lead wires in same position as old coil.)  
B) Insert plunger guide.

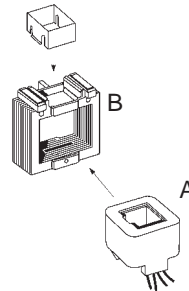

- 6** A) Re-insert plunger into coil; drop pivot pin into cradle of support plate.  
B) Remove screwdriver.

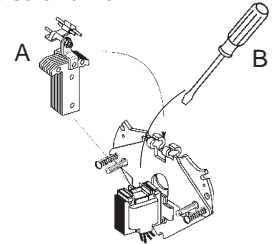

Reconnect coil and replace housing per installation instructions, page 2.

## VERTICAL SPRING ASSEMBLY

### Vertical Brake Assembly

Single disc brakes (3 & 6 lb-ft) are universal mount and do not require separator springs. Double disc brakes (10-15 lb-ft.) are universal mount but require separator springs which are preassembled to the stationary disc. These discs are inserted spring first into the brake. Refer to figure 2A.

### 2 Friction Disc

Vertical Above  
Vertical Below

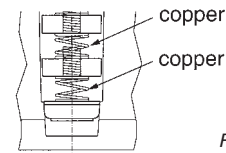

Figure 2A

## TORQUE ADJUSTMENT

### Torque Adjustment

Brake is factory set for nominal rated static torque which is maximum torque. Torque may be decreased up to 50% for increased stopping times up to 2 second stop time.

Turn both spring adjustment screws (11), Figure 3, equal amounts counterclockwise to decrease torque. See Table A for torque reduction permissible amounts.

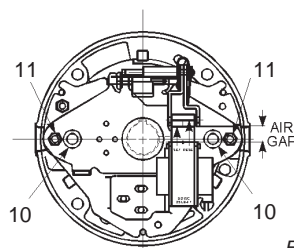

Figure 3

Table A

| Nominal Static Torque (lb-ft) | Original Spring Height (inches) | Maximum Counter-clockwise Turns | % Torque Reduction Per Turn |
|-------------------------------|---------------------------------|---------------------------------|-----------------------------|
| 3                             | 1.47                            | 7                               | 7%                          |
| 6                             | 1.47                            |                                 |                             |
| 10                            | 1.53                            |                                 |                             |
| 15                            | 1.53                            |                                 |                             |

# TROUBLESHOOTING

| COIL FAILURE   |   |
|--|---|
| SUPPLY VOLTAGE CAUSE   | SUPPLY VOLTAGE CORRECTION   |
| Line voltage >110% of coil rating  | Reduce voltage or replace with proper rated coil  |
| Excessive voltage drop during inrush time  | Increase current rating of power supply.  |
| WIRING CAUSE   | WIRING CORRECTION   |
| Leadwires interfering with plunger pull-in   | Reroute wiring away from plunger and other moving components.                             |
| Excessive voltage drop during inrush time  | Increase leadwires size from power supply   |
| Coil leadwire shorted to ground  | Replace coil or leadwire and protect with wire sleeving                                   |
| SOLENOID ASSEMBLY CAUSE  | SOLENOID ASSEMBLY CORRECTION  |
| Plunger not seating flush against solenoid frame   | Loosen solenoid mounting screws and reposition frame to allow full face contact           |
| Plunger cocked in coil preventing pull-in  | Realign solenoid frame  |
| Excessive solenoid/plunger wear at mating surface  | Replace solenoid assembly   |
| Broken shading coils   | Replace solenoid assembly   |
| WORN PARTS CAUSE   | WORN PARTS CORRECTION   |
| Excessive wear of solenoid link arm and/or shoulder bolt                                     | Replace link arm and link bolt; also inspect plunger thru-hole for elongation             |
| Plunger guides worn down and interfering with plunger movement                               | Replace guides  |
| APPLICATION CAUSE  | APPLICATION CORRECTION  |
| Machinery cycle rate is exceeding brake rating   | Reduce brake cycle rate or use alternate control method                                   |
| High ambient temperature (>110%) and thermal load exceeding coil insulation rating           | Use Class H rated coil and /or find alternate method of cooling brake                     |
| Brake coil wired with windings of an Inverter motor or other voltage/current limiting device | Wire coil to dedicated power source with instantaneous coil rated voltage limiting device |
| MISCELLANEOUS CAUSE  | MISCELLANEOUS CORRECTION  |
| Wrong or over tightened torque   | Replace with proper spring or refer to Installation section for proper spring height      |
| Excessive air gap  | Reset, refer to Installation Section 4  |

| EXCESSIVE WEAR / OVERHEATING  |   |
|---|---|
| AIR GAP CAUSE   | AIR GAP CORRECTION  |
| Low solenoid air gap  | Reset air gap (refer to Air Gap Adjustment)   |
| Disc pack dragging  | Inspect endplate, hub and discs for dirt, burrs, wiring and other sources of interference preventing disc "float" |
| CYCLE RATE CAUSE  | CYCLE RATE CORRECTION   |
| Brake "jogging" exceeding coil cycle rate   | Reduce cycle rate or consider alternate control method  |
| Thermal capacity is being exceeded  | Reduce cycle rate, use alternate control method or increase brake size  |
| ALIGNMENT CAUSE   | ALIGNMENT CORRECTION  |
| Broke endplate not concentric to motor C-Face                                     | Motor register must be within .004" on concentricity;   |
| Motor shaft runout is excessive   | Must be within .002"; runout; consult motor manufacturer  |
| Brake is being operated on an incline greater than 15° above or below horizontal  | Vertical separator springs must be used to prevent discs from becoming cocked                                     |
| WORN PARTS CAUSE  | WORN PARTS CORRECTION   |
| Friction disc excessively worn (disc can wear to 1/2 original thickness or .093") | Replace friction discs.   |
| Endplate, stationary disc or pressure plate warped                                | Replace warped or worn component  |
| Linkages and/or pivot pins worn   | Replace all worn components   |
| Motor shaft endfloat excessive  | Endfloat must not exceed .020"; consult motor manufacturer  |
| HUB CAUSE   | HUB CORRECTION  |
| Burr on hub interfering with disc "float"   | File off burr   |
| Set screw backed out and interfering with disc                                    | Retighten set screw; use Loctite® 242 to help secure  |
| MISCELLANEOUS   | MISCELLANEOUS   |
| Solenoid plunger not pulling completely   | Check line voltage (±10% of nameplate rating) or replace worn solenoid assembly                                   |
| Wiring is restricting disc pack movement  | Reroute wiring  |
| Excessive stop time (2 seconds or greater)  | Increase brake size/torque or use alternate control method  |
| High Ambient temperature (in excess of 110°F)                                     | Reduce cycle rate or use alternate method of cooling  |
| Moisture in brake   | Remove drain plug (WASHGUARD brakes only). After fluid has drained replace plug                                   |

| PART NUMBERS | Torque    | Leeson Part Number | Stearns Part Number | Brake Coil Rating (VAC) | NEMA Enclosure | Brake Bore/ Shaft Diameter (X/U) | NEMA Frame Size | Dimension A |
|--------------|-----------|--------------------|---------------------|-------------------------|----------------|----------------------------------|-----------------|-------------|
|              | lb. ft.   |                    |                     |                         |                |                                  |                 |             |
| 3            | 175563.00 | 1056711051PF       |                     | 115/208-230             | 2              | 5/8" / 5/8"                      | 56C             | 4.91"       |
|              | 175564.00 | 1056711051QF       |                     | 208-230/460             | 2              | 5/8" / 5/8"                      | 56C             | 4.91"       |
|              | 175565.00 | 1056711051NF       |                     | 575                     | 2              | 5/8" / 5/8"                      | 56C             | 4.91"       |
|              | 175566.00 | 1056714051PF       |                     | 115/208-230             | 4X             | 5/8" / 5/8"                      | 56C             | 4.94"       |
|              | 175567.00 | 1056714051QF       |                     | 208-230/460             | 4X             | 5/8" / 5/8"                      | 56C             | 4.94"       |
|              | 175568.00 | 1056714051NF       |                     | 575                     | 4X             | 5/8" / 5/8"                      | 56C             | 4.94"       |
| 6            | 175569.00 | 1056721081PF       |                     | 115/208-230             | 2              | 7/8" / 5/8"                      | 56C/143-5TC     | 4.91"       |
|              | 175570.00 | 1056721081QF       |                     | 208-230/460             | 2              | 7/8" / 5/8"                      | 56C/143-5TC     | 4.91"       |
|              | 175571.00 | 1056721081NF       |                     | 575                     | 2              | 7/8" / 5/8"                      | 56C/143-5TC     | 4.91"       |
|              | 175572.00 | 1056724081PF       |                     | 115/208-230             | 4X             | 7/8" / 5/8"                      | 56C/143-5TC     | 4.94"       |
|              | 175573.00 | 1056724081QF       |                     | 208-230/460             | 4X             | 7/8" / 5/8"                      | 56C/143-5TC     | 4.94"       |
|              | 175574.00 | 1056724081NF       |                     | 575                     | 4X             | 7/8" / 5/8"                      | 56C/143-5TC     | 4.94"       |
| 10           | 175575.00 | 1056731081PF       |                     | 115/208-230             | 2              | 7/8" / 5/8"                      | 56C/143-5TC     | 4.91"       |
|              | 175576.00 | 1056731081QF       |                     | 208-230/460             | 2              | 7/8" / 5/8"                      | 56C/143-5TC     | 4.91"       |
|              | 175577.00 | 1056731081NF       |                     | 575                     | 2              | 7/8" / 5/8"                      | 56C/143-5TC     | 4.91"       |
|              | 175578.00 | 1056734081PF       |                     | 115/208-230             | 4X             | 7/8" / 5/8"                      | 56C/143-5TC     | 4.94"       |
|              | 175579.00 | 1056734081QF       |                     | 208-230/460             | 4X             | 7/8" / 5/8"                      | 56C/143-5TC     | 4.94"       |
|              | 175580.00 | 1056734081NF       |                     | 575                     | 4X             | 7/8" / 5/8"                      | 56C/143-5TC     | 4.94"       |
| 15           | 175581.00 | 1056741071QF       |                     | 208-230/460             | 2              | 7/8" / 7/8"                      | 143-5TC         | 4.91"       |
|              | 175582.00 | 1056744071QF       |                     | 208-230/460             | 4X             | 7/8" / 7/8"                      | 143-5TC         | 4.94"       |