

Series 56,800 (1-056-8XX)
Division 2 Hazardous Location
Mounting Face: NEMA 56C, 143TC and 145TC
4.5" AK, 5.88" AJ



Static Torque: 1.5 through 25 lb-ft
Enclosure Material: Cast Iron
Release Type: Side Lever, maintained with auto reset
Enclosure Protection: IP 54
Certified: UL Listed, File E 14893 for Class 1, Division 2, Groups A, B, C, D, and Class II, Division 2, Groups F and G
Mounting Requirements: 1-056-8X2 Series Hazardous Location Motor Mounted Brake is recommended for mounting close coupled to the motor end bell. The acceptability of the brake and motor combination must be determined by Underwriters Laboratory.
Universal Mounting: Through 15 lb-ft. 20 and 25 lb-ft. supplied with springs for vertical modification.

Epoxy Encapsulated Coil Construction, with Class H Insulation

NC Thermostat

Maximum speed:
 Horizontal 5000 rpm
 Vertical 3600 rpm

Installation, Service and Parts List:
 P/N 8-078-905-18

ABS Type Approval Certified
 Brake set and release times in milliseconds, when brake and motor are switched separately (for T1/T2 definitions, see page 98):

Static Torque	Coil Size	T1	T2
1.5 - 25	4, K4, K4+, M4+	25	14

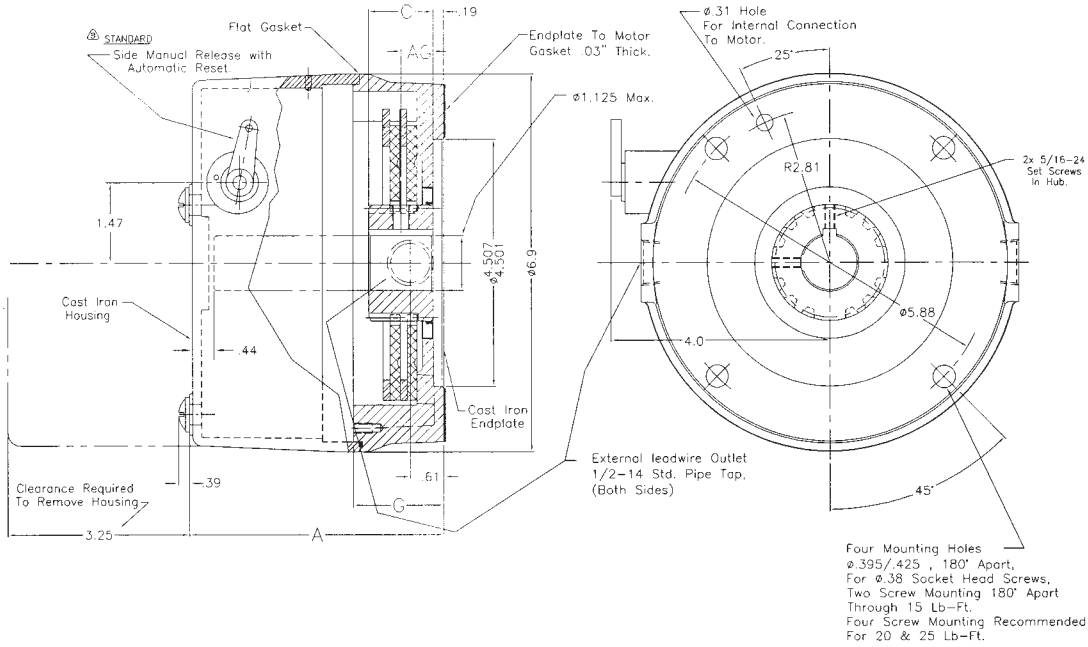

Dimensions for estimating only. For installation purposes request certified prints.

Motor Frame Adapters

WARNING! Before selecting an adapter to mount a brake on a larger motor frame, the torque and thermal capacity required by the application should be determined as shown in the "Selection Procedure" section. A larger motor may indicate a requirement for greater thermal capacity than the brake is designed for. The brake selection must be matched to the motor and application requirements, before use of an adapter is considered.

To Adapt to NEMA Frame Size	AK Dim.	Reg. No.	Brake Torque	Adapter Stock Number	Additional Shaft Length Required
	in. (mm)				in. (mm)
182TC 184TC 213TC 215TC	8.50 (215.90)	-9	1.5-6	5-55-5041-00 List \$700	.94 (23.81)
254TC 256TC	8.50 (215.90)	-9	10-25	5-55-5043-00 List \$700	.94 (23.81)

For adapter dimensions, see *Technical Data*.

Unit Pricing (Discount Symbol B4)

Model Number	Nominal Static Torque (lb-ft) (Nm)	Dimensions in Inches (Dimensions in Millimeters)				Enclosure	List Price	Wt. lbs (kg)
		A	AG	C	G			
1-056-802-00	1.5 (2)	4.37 (111.0)	.47 (11.9)	.81 (20.6)	1.21 (30.7)	IP 54	\$1,540.00	15
1-056-812-00	3 (4)	4.37 (111.0)	.47 (11.9)	.81 (20.6)	1.21 (30.7)	IP 54	1,550.00	15
1-056-822-00	6 (8)	4.37 (111.0)	.47 (11.9)	.81 (20.6)	1.21 (30.7)	IP 54	1,615.00	15
1-056-832-00	10 (14)	4.82 (122.4)	.59 (15.0)	1.18 (30.0)	1.66 (42.2)	IP 54	1,720.00	17
1-056-842-00	15 (20)	4.82 (122.4)	.59 (15.0)	1.18 (30.0)	1.66 (42.2)	IP 54	1,820.00	17
1-056-852-00	20 (27)	4.82 (122.4)	.59 (15.0)	1.18 (30.0)	1.66 (42.2)	IP 54	1,905.00	21
1-056-862-00	25 (34)	4.82 (122.4)	.59 (15.0)	1.18 (30.0)	1.66 (42.2)	IP 54	2,000.00	21

Engineering Specifications

Nominal Static Torque	No. of Friction Discs	Coil Size	Maximum Solenoid Cycle Rate ^①	Thermal Capacity ^②	Inertia (Wk ²)
lb-ft (Nm)		AC	cycle/min	hp-sec/min (watts)	lb-ft ² (kgm ² x 10 ⁻⁴)
			AC	Horizontal	
1.5 (2)	1	4	7.5	3.5 (43.50)	.008 (3.36)
3 (4)	2	4	7.5	3.5 (43.50)	.014 (5.88)
6 (8)	2	4	7.5	3.5 (43.50)	.014 (5.88)
10 (14)	2	K4	7.5	3.5 (43.50)	.014 (5.88)
15 (20)	2	K4+	7.5	3.5 (43.50)	.014 (5.88)
20 (27)	3	K4+	7.5	3.5 (43.50)	.020 (8.40)
25 (34)	3	M4+	7.5	3.5 (43.50)	.020 (8.40)

- ① Maximum solenoid cycle rate is based on ambient temperature of 104°F (40°C) with 50% duty cycle. Does relate to brake cycle rate (see *Thermal Capacity*).
- ② Thermal capacity rating is based on ambient temperature of 104°F (40°C), stop time of one second or less, with no heat absorbed from motor. Derate thermal capacity by 25% for vertical mounting. Refer to *Selection Procedure* Section.

Current Ratings (amperes)

Solenoid Coil Size	AC Current	Voltage: 60 Hz						Voltage: 50 Hz		
		115 Vac	200 Vac	230 Vac	400 Vac	460 Vac	575 Vac	110 Vac	220 Vac	380 Vac
4	Inrush	3.6	2.1	1.8	1.1	.9	.7	4.1	2.1	.9
	Holding	.3	.2	.2	.08	.08	.06	.3	.2	.08
K4	Inrush	4.3	2.5	2.2	1.3	1.1	.9	3.8	1.9	1.1
	Holding	.3	.2	.2	.1	.08	.07	.4	.2	.08
K4+	Inrush	4.6	2.5	2.3	1.2	1.0	.9	4.9	2.0	1.0
	Holding	.4	.2	.2	.1	.1	.08	.4	.2	.1
M4+	Inrush	4.6	2.5	2.3	1.2	1.0	.9	4.1	2.0	1.3
	Holding	.4	.2	.2	.1	.1	.08	.4	.2	.1

Ordering and Identification Information

The following example and tables provide information for selecting the appropriate three-letter suffix when ordering a Stearns Brake.

Example of a complete part number: 1-056-832-00-BFF — Lead wire position (internal and external, left and right)
 — 230 Vac
 — 5/8 bore and 3/16 x 3/32 keyway

Hub Selection

Character	Bore (in.)	Keyway** (in. x in.)
A*	5/8	1/8 x 1/16
B	5/8	3/16 x 3/32
C	3/4	3/16 x 3/32
D	7/8	3/16 x 3/32
E	1-1/8	1/4 x 1/8
F*	1-1/4	1/4 x 1/8
K	1/2	1/8 x 1/16
L*	1	1/4 x 1/8
N*	9/16	1/8 x 1/16
O*	11/16	3/16 x 3/32
P*	1-1/6	1/4 x 1/8
R*	13/16	3/16 x 3/32
S*	15/16	1/4 x 1/8

Maximum allowable bore 1.25. For thru-shaft applications, .875 is maximum.

*These bores are non-standard. Add \$225.00 to list price.

**Keyseats made to ANSI B17.1 standard.

Standard AC Voltage Ratings

Character	Voltage	Hz
B	115	60
D	110	50
E	200	60
F	230 190	60 50
H	220	50
L	460 380	60 50
M	415	50
N	575	60
O	110/220	50
P	115 230	60
Q	230/460 190/380	60
R	200/400	60

DC voltages not available.

Space heater not available.

Modifications are available- see SAB Modification Section

SELECTION - Solenoid Actuated Brakes

NOTE: For overhauling/high inertia loads, to stop in a specified time/distance, or for brakes combined with variable frequency drives, please refer to *Application Engineering Section*.

Stearns Solenoid Actuated Brakes can be easily selected from Table 1 and 2.

Given motor data:

1. Horsepower (hp)
2. Speed (RPM)
3. NEMA C-face frame size

Determine:

1. Static torque rating of the brake (lb-ft)
2. Brake series

Step 1 – Given the motor horsepower and speed, select the brake torque from Table 1. Torque in table 1 is calculated using formula:

$$T_s = \frac{5,252 \times P}{N} \times SF$$

Where, T_s = Static torque, lb-ft

P = Motor horsepower, hp

N = Motor full load speed, rpm

SF = Service Factor

5,252 = constant

Example: Given a 5 hp, 1800 RPM motor, the selected brake is 20 or 25 lb-ft.

Step 2 – Given the NEMA C-face motor frame size, select the brake series from Table 2.

Example: Given the 5 hp, 1800 RPM motor in Step 1 with a NEMA 184TC frame, Series 87,000; 87,300 or 87,700 Brakes can be selected to mount directly to the motor.

Table 1 – Torque Selection

In this table, brake torque ratings are no less than 140% of the motor full load torque.

Motor hp	Brakemotor Shaft Speed (RPM)						
	700	900	1200	1500	1800	3000	3600
	Static Torque Rating of Brake (lb-ft)						
1/6	3	1.5	1.5	1.5	0.75	0.5	0.5
1/4	3	3	3	1.5	1.5	0.75	0.5
1/3	6	3	3	3	1.5	1.5	0.75
1/2	6	6	3	3	3	1.5	1.5
3/4	10	6	6	6	6	3	3
1	15	10	6	6	6	3	3
1-1/2	20	15	10	10	10	6	3
2	25	20	15	10	10	6	6
3	35	25	20	15	15	10	6
5	75	50	35	25	20 or 25	15	10
7-1/2	105	75	50	50	35	25	15
10	105	105	75	50	50	25	25
15	175	125	105	75	75	50	35
20	230	175	125	105	105	50	50
25	330	230	175	125	105	75	50
30	330	330	230	175	125	75	75
40	440	330	330	230	175	105	105
50	550	440	330	330	230	*	*
60	750	500	440	330	330	*	*
75	1000	750	500	440	330	*	*
100	—	1000	750	500	440	*	*
125	—	1000	1000	750	500	*	*
150	—	—	1000	750	750	*	*
200	—	—	—	1000	1000	*	*
250	—	—	—	—	1000	*	*

*See catalog pages for maximum rpm by series. Thermal capacity must be considered in load stops over 1800 rpm.

Table 2 – Brake Series Selection by NEMA Frame Size

Torque Range (lb-ft)	Brake Series	C-Face Motor Frame Size											
		48C	56C	143TC 145TC	182TC 184TC	213TC 215TC	254TC 254UC 256TC 256UC	284TC 284UC 286TC 286UC	324TC 324UC 326TC 326UC	364TC 364UC 365TC 365UC	404TC 404UC 405TC 405UC	444TC 444UC 445TC 445UC	504UC 504SC 505C 505SC
Manually-Adjusted Brakes (require periodic adjustment to compensate for friction disc wear)													
1.5-6 1.5-25 10-25	48,100 56,X00 56,500	①	①	①	② ①	②	②						
Self-Adjusting Brakes (automatically compensate for friction disc wear)													
6-105 50-105 125-230 125-440 500-1000 500-1000	87,X00 87,100 81,000 82,000 86,000 86,100		③	③	① ②	① ②	① ② ②	② ② ②	② ① ① ②	② ① ① ②	② ① ① ②	② ② ① ①	①
Division I Hazardous Location Brakes (for atmospheres containing explosive gases or ignitable dusts) / Motor Mounted													
1.5-15 10-105 125-330	65,300 87,300 82,300		①	①	② ① ②	② ① ②	② ① ②	② ② ②	② ② ①	② ② ①	② ② ①	②	
Division I Hazardous Location Brakes (for atmospheres containing explosive gases or ignitable dusts) / Foot Mounted													
10-105 125-330	87,300 82,300				④	④	④		④	④	④		
Division 2 Hazardous Location Brakes													
1.5-25 6-105	56,800 87,800		① ③	① ③	② ①	② ①	② ①	②	②	②	②		
Double C-Face Brake Couplers (for direct coupling a C-face motor to a C-face gear reducer)													
1.5-25 10-105	56,700 87,700		①	①	①	①	①						

- ① Brake mounts directly to motor C-face.
- ② Adapter required to mount brake to motor C-face. Refer to brake specifications for adapter information.
- ③ Brake endplate modified for direct mounting to motor C-face without an adapter.
- ④ Brake is foot mounted for coupling to a hazardous-location motor.

Hazardous Location Brakes

Enclosures for standard Stearns disc brakes are designed to prevent accidental contact with the internal mechanism while keeping contaminants from the operating parts. Many installations, however, require additional protection due to the presence of explosive gases or ignitable dusts in the atmosphere. Hazardous locations are defined in the National Electrical Code (NEC) and designated by Class, Division and Group. For a better understanding of hazardous locations, or for definitions of hazardous location terminology, please refer to: <http://www.ul.com/global/eng/pages/offerings/services/hazardouslocations/>.

- **Class I** – Locations where the atmosphere may contain flammable gases or vapors in explosive or ignitable concentrations. An electric disc brake for Class I locations must be built in such a manner that any ignition of gases or vapors within the brake will not result in rupture of the enclosure or allow a flame or spark to travel from within the brake to the surrounding hazardous atmosphere.
- **Class II** – Locations with combustible dust in suspension in the atmosphere. An electric disc brake for Class II locations must be enclosed in a manner which precludes entry of ignitable dusts or exit of any arcs, sparks, or hot gases which may cause ignition of dusts suspended in the surrounding atmosphere or accumulated on the enclosure. The exterior surface temperature of the brake enclosure must be limited so that it can function at its maximum-rated duty cycle without causing dehydration or carbonization of dust that accumulates on the enclosure.
- **Divisions** – Each hazardous-location Class is also divided into two Divisions, 1 and 2. Division 1 is a *normally* hazardous location. Division 2 is normally *not* hazardous. Division 1 brakes can be used in both types of locations. **Division 2 can be used in Division 2 environments ONLY.**
- **Groups** – Class I gases and vapors are listed in four Groups A, B, C and D, based on specific properties such as maximum explosion pressure and ignition temperature. Class II airborne dusts are listed in three Groups: E, F, and G. The dust properties considered include thermal and electrical conductivity and ignition temperature.

Selection

When specifying a Stearns hazardous-location disc brake, the Class and Group designations of the hazardous atmosphere and its ignition temperature must be known. The selection table gives the hazardous atmospheres that Stearns brakes are suitable for, along with the brake's maximum operating

temperature. For more information on hazardous location responsibilities, see: <http://www.ul.com/global/eng/pages/offerings/services/hazardouslocations/>

Step 1 – Determine the Class and Group designation of the hazardous atmosphere.

Step 2 – For Class I hazardous substances, determine the ignition temperature of the explosive gas or vapor. Select a brake listed for the appropriate group with a maximum external surface temperature that does *not* exceed the ignition temperature of the explosive gas or vapor.

Step 3 – For Class II hazardous substances, select a brake listed for the appropriate group.

Ignition temperatures of Combustible Dusts may be found in NFPA publication NFPA 499 Recommended Practice for the Classification of Combustible Dusts and of Hazardous (Classified) Locations for Electrical Installations in Chemical Process Areas. Ignition temperatures of Flammable Liquids, Gases and Vapors may be found in NFPA publication NFPA 497 Recommended Practice for the Classification of Flammable Liquids, Gases and Vapors and of Hazardous (Classified) locations for Electrical Installations in Chemical Process Areas.

Brake Labels and Listing

Stearns brakes for use in hazardous locations are marked to show the Class, Group, and maximum Class II operating temperature (in a 40°C ambient) of the brake enclosure, as well as the minimum Class I ignition temperature of the gases or vapors to which they can be exposed.

Generally, compliance with the NEC is demonstrated by UL Listing of the product in Underwriters Laboratories Hazardous Location Equipment Directory. A label displaying the UL Listing mark and required rating information will be found on each Stearns brake to confirm the Listing.

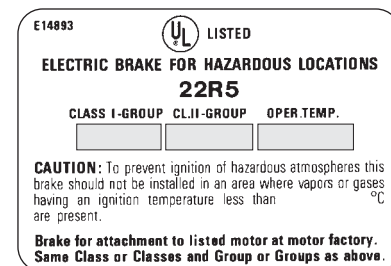

In Canada, the Canadian Standards Association (CSA) is an organization with the responsibility to publish and administer national electrical standards as well as to test and certify electrical products. The CUL or CSA monogram will be found on Stearns hazardous-location brakes sold in Canada to confirm certification.

Stearns motor-mounted, hazardous-location electric disc brakes are Listed only when mounted directly to a Listed hazardous-location motor of the same Class and Group at the motor manufacturer's facility, and where the combination has been accepted by UL. This

procedure completes the explosion-proof assembly of the brake. However, *foot-mounted* Listed hazardous-location disc brakes are also available for coupling to a motor, and may be installed by anyone.

These brakes are listed by UL (Underwriters Laboratories, Inc.,) for use in certain locations classified as hazardous. Installation and servicing must be in compliance with all existing local safety codes. All wiring and electrical connections must comply with the National Electric Code (NEC) and local electrical codes in effect at the time. For additional information see the Underwriters Laboratories (UL) website <http://www.ul.com/hazloc/codes/html>.

HazLoc inspection authorities are responsible for verifying and authorizing the use of suitably designed, manufactured and installed HazLoc equipment. When questions arise always consult the local Authority Having Jurisdiction (AHJ) for directions and approvals.

Hazardous-Location Brake Enclosures

Division 1, hazardous location brakes are typically provided with machined components, without gaskets. Series 65300 brakes can be provided with gaskets to meet IP 55, 56 or Type 4 enclosure protection. Series 87300 brakes can be provided with gaskets to meet IP 55, 56 or 57 enclosure protection. Series 82300 can be provided with IP 56 enclosure protection. All Division 1 enclosures prevent flame propagation to the outside atmosphere through tortuous flame paths having controlled clearances. If the brake is used in a high humidity or low temperature environment, internal electric heaters should be used.

Division 2 hazardous location brakes are provided with an IP 55 enclosure. Heater and proximity switch options are limited to Division 2, Class II brakes.

Thermal Considerations

A major design requirement of hazardous-location brakes is to limit exterior surface temperature. The surface temperature of the enclosure must not exceed a specified limit as a result of heat energy created in stopping the motor and load. This NEC restriction on the exterior surface temperature limits the hazardous-location brake's ability to dissipate heat, resulting in less thermal capacity than a comparable brake with a standard or dust-tight, waterproof enclosure.

THEREFORE, HAZARDOUS-LOCATION BRAKES ARE INTENDED ESSENTIALLY FOR NON-CYCLIC OR HOLDING PURPOSES, BUT MAY BE USED FOR STOPPING LIGHT INERTIAL LOADS.

Hazardous Location Brake Selection Table

Classification		Minimum Auto-Ignition Temperature of Atmosphere	Minimum Layer or Cloud Ignition Temperature	T Code	Brake Series Division 1	Brake Series Division 2	
Class	Group						
I	A	160°C / 320°F		T3C		56800, 87800	
	B	160°C / 320°F		T3C		56800, 87800	
	C		100°C / 212°F		T5	87300	
			160°C / 320°F		T3C		56800, 87800
			180°C / 356°F		T3A	65300, 82300	
	D		100°C / 212°F		T5	87300	
			160°C / 320°F		T3C		56800, 87800
		180°C / 356°F		T3A	65300, 82300		
II	E		100°C / 212°F	T5	87300		
			165°C / 329°F	T3B	65300*, 82300*		
	F		100°C / 212°F	T5	87300		
			160°C / 320°F	T3C		56800, 87800	
			165°C / 329°F	T3B		87800	
	G		165°C / 329°F	T3B	65300, 82300		
			100°C / 212°F	T5	87300		
			160°C / 320°F	T3C		56800, 87800	
			165°C / 329°F	T3B		87800	
			165°C / 329°F	T3B	65300, 82300		

NOTE: Models with asterisk (*) group E available in select models only, consult factory.

*Series 65,300-07 (New Design Close Coupled) and 65,300-09 (Fan Guard Mount) are Class I Group C and D, Class II Group F and G only
 Maximum exterior surface temperature is based on operation in an ambient of 104°F (40°C).

65,300 and 87,300 & 82,300 Circuit Diagram

These brakes rely on a thermostat switch wired to the motor control circuit to limit the brake's enclosure surface temperature. Refer to the circuit diagram. If the brake begins to overheat, the thermostat TSW2 switch will open and interrupt the motor starter and brake solenoid current, causing the brake to set. A second thermostat TSW1 will close on Series 65,X00, or will open on Series 87,300** and 82,300** brakes. The TSW1 switch can be used to actuate alarm or warning light. This switch actuates at a lower temperature than TSW2, and will alert the equipment operator of an impending thermal overload.

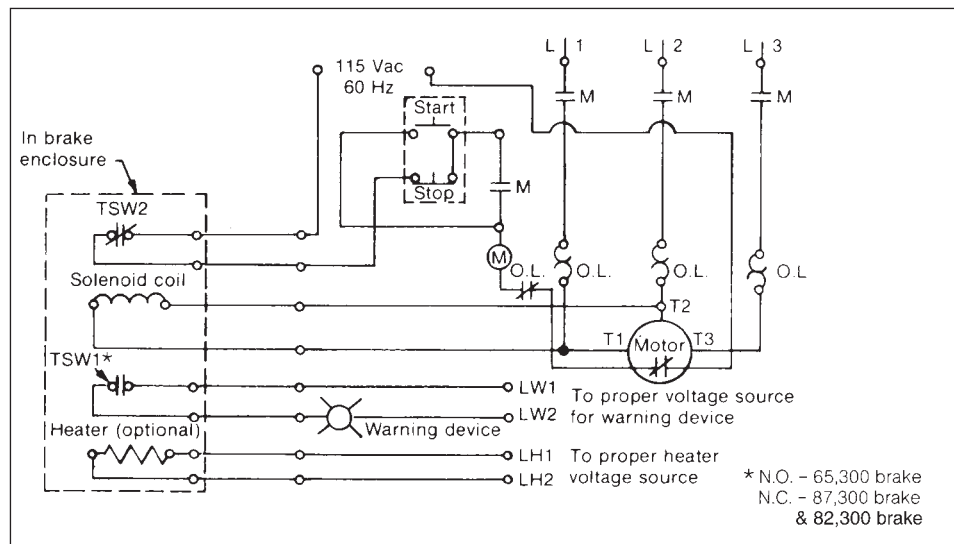

*N.O. - 65,300 brake
 N.C. - 87,300 brake
 & 82,300 brake

**TSW1 is optional on 87,300 and 82,300 series brakes.

Stearns® Spring-Set Disc Brakes

Installation, Service and Parts List Series 56,800 for Class I & II, Division 2 Manual Adjust Brakes Rev: A & B

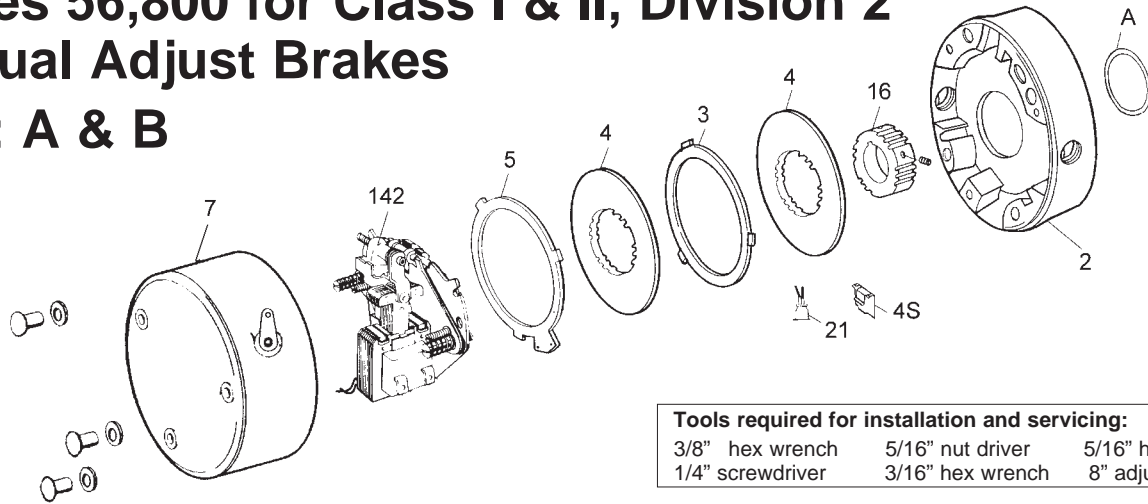

Tools required for installation and servicing:

3/8" hex wrench	5/16" nut driver	5/16" hex wrench
1/4" screwdriver	3/16" hex wrench	8" adjustable wrench

Typical Nameplate

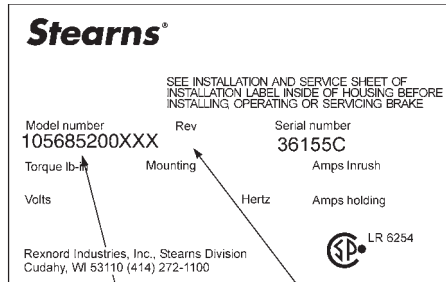

MODEL NUMBER
Refer to actual nameplate on brake for additional information

REVISION CONTROL
(if applicable) and Brake Serial Number

IMPORTANT

Please read these instructions carefully before installing, operating, or servicing your Stearns Brake. Failure to comply with these instructions could cause injury to personnel and/or damage to property if the brake is installed or operated incorrectly. For definition of limited warranty/liability, contact Rexnord Industries, LLC, Stearns Division, 5150 S. International Dr., Cudahy, WI 53110, (414) 272-1100.

Caution

1. Installation and servicing must be made in compliance with all local safety codes including Occupational Safety and Health Act (OSHA). All wiring and electrical connections must comply with the National Electric Code (NEC) and local electric codes in effect. For additional information refer to the Underwriters Laboratory (UL) website at: <http://www.ul.com/hazloc/codes.html>
2. This brake may not be suitable for use in certain atmospheres containing explosive gases and dusts. **HazLoc** inspection authorities are responsible for verifying and authorizing the use of suitably designed and installed **HazLoc** equipment. When questions arise consult local Authority Having Jurisdiction (AHJ).
3. To prevent an electrical hazard, disconnect power source before working on the brake. If power disconnect point is out of sight, lock disconnect in the off position and tag to prevent accidental application of power.

4. Make certain power source conforms to the requirements specified on the brake nameplate.
5. Be careful when touching the exterior of an operating brake. Allow sufficient time for brake to cool before disassembly. Surfaces may be hot enough to be painful or cause injury.
6. Do not operate brake with housing removed. All moving parts should be guarded.
7. Installation and servicing should be performed only by qualified personnel familiar with the construction and operation of the brake.
8. For proper performance and operation, only genuine Stearns parts should be used for repairs and replacements.
9. After usage, the brake interior will contain burnt and degraded friction material dust. This dust must be removed before servicing or adjusting the brake.

DO NOT BLOW OFF DUST using an air hose. It is important to avoid dispersing dust into the air or inhaling it, as this may be dangerous to your health.

- a) Wear a filtered mask or a respirator while removing dust from the inside of a brake.
- b) Use a vacuum cleaner or a soft brush to remove dust from the brake. When brushing, avoid causing the dust to become airborne. Collect the dust in a container, such as a bag, which can be sealed off.

General Description

This brake series is spring-set, electrically released. It contains one or more rotating friction discs (4) driven by a hub (16) mounted on the motor or other shaft.

The brake is Listed by Underwriters Laboratories, Incorporated for Division 2 - normally not hazardous location. The Class and Group designation is shown on nameplate. The listing includes brakes for attachment to TENV or TEFC motor.

The listing marks on the brake apply only to the brake, not to the driving equipment. In the case of another mounted brake, neither brake nor motor are Listed unless both are Listed.

The listing marks of both the brake and the motor must be in agreement as to the Class and Group rating.

Note: Fanguard-mounted brakes requiring IP54 & IP55 protection may require additional sealing measures beyond seals provided with this brake. Pressurized sprays aimed at the fan and brake hub surfaces can result in fluid migration along the motor shaft and keyway, and into the brake. The use of an appropriate sealant, such as RTV, or a *forsheda* seal is advised.

Operating Principle

This brake series contains one or more friction discs (4) assembled alternately between the endplate (2) friction surface, stationary disc(s) (3) and pressure plate (5). The stationary disc(s) are restrained from rotating by being keyed into the endplate. With the brake released, all disc pack components are free to slide axially and the friction disc(s) to rotate.

Brake release occurs when the solenoid coil is electrically energized, causing the solenoid plunger to travel a specified distance and through a lever system, overcoming the pressure spring force. This action releases the clamping force on the disc pack, thereby allowing the friction disc(s) and brake hub to rotate.

Brake sets and torque is produced when electric current to the solenoid coil is interrupted, thereby collapsing the solenoid magnetic field. The solenoid plunger returns to its original de-energized position allowing the lever arm to move forward by virtue of the compressed torque springs. This action compresses the disc pack components which applies a retarding torque to the brake hub and ultimately restores the brake to a spring-set static condition.

Caution 1: While the brake is equipped with a manual release to allow manual shaft rotation, the motor should not be run with the manual release engaged, to avoid overheating the friction disc(s).

Caution 2: Do not operate manual release until brake is installed to preserve alignment of friction disc(s) for ease of brake assembly.

1 Place hub on motor shaft.

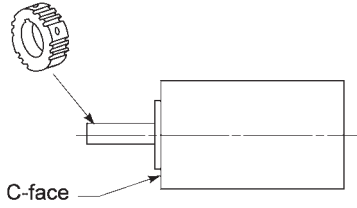

2 Position hub on shaft as shown.

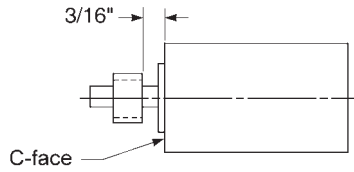

3 Tighten set screws to motor shaft.

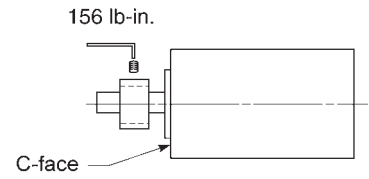

4 Remove brake housing and gasket.

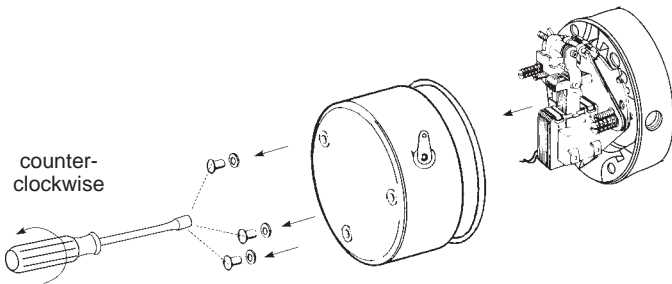

5 Slide endplate over hub noting position of stabilizer springs, if used. (Refer to Friction Disc Replacement, View 4 and 4A.)

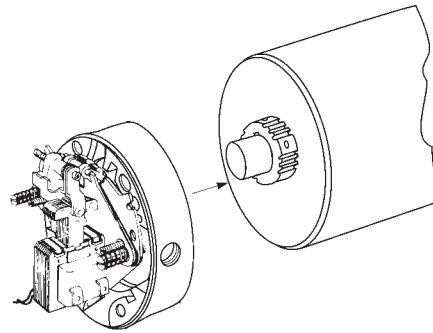

6 Mount brake endplate to motor C-face.

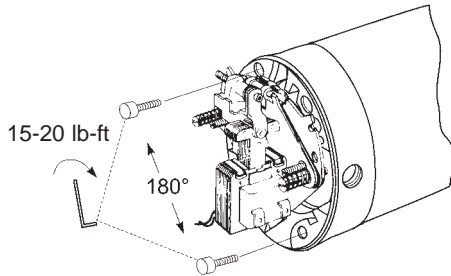

* For vertical assembly of 20 & 25 lb-ft brakes, refer to page 5.

7 Connect coil leadwires to power supply. Refer to nameplate for voltage rating.*
Caution: Keep wiring away from pinch points and moving components.

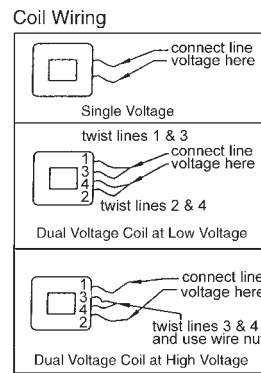

* Refer to Figure 7 (page 5) for control circuit wiring.

8 Replace brake housing and gasket and tighten to 12 lb-in.

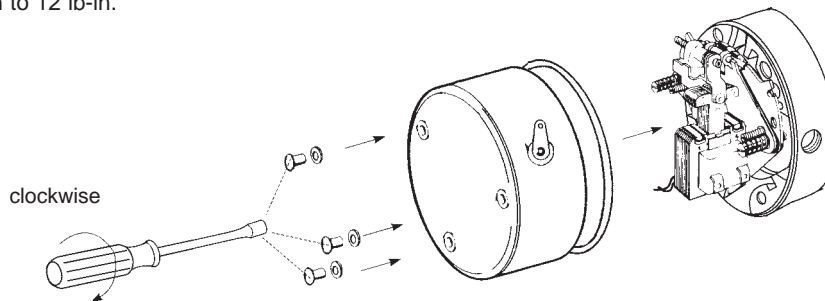

AIR GAP ADJUSTMENT

Series 56,800

As friction disc wear the air gap will increase. When plunger gets to the reset position, the air gap must be adjusted.

- 1** To **increase** air gap, turn both adjusting screws (10) counterclockwise.

56,X00 Series Air Gap*

Disc	Torque	Min/Max
1.5, 3 & 6	1.5, 3 & 6	.38" - .69"
10 & 15	10 & 15	.45" - .69"
20 & 25	20 & 25	.50" - .69"

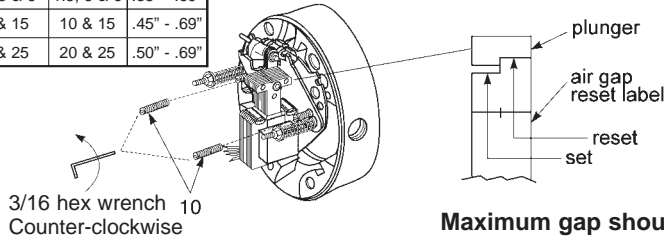

- 2** To **decrease** air gap, turn both adjusting screws (10) clockwise.

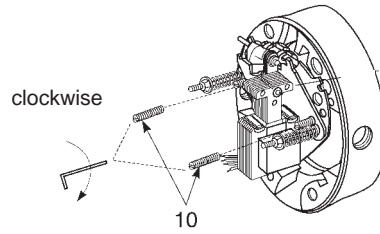

FRICITION DISC REPLACEMENT

Series 56,800

- 1** Remove brake housing and gasket.

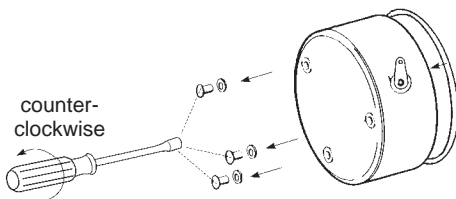

- 2** Remove support plate screws and lift support from brake.

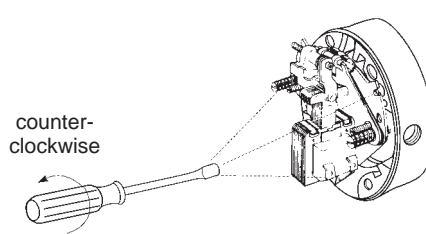

- 3** Remove and discard old friction disc.

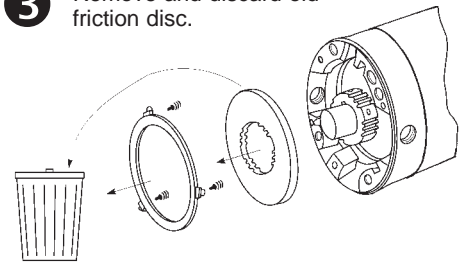

- 4** Install new friction disc(s) and stationary disc(s) as shown.

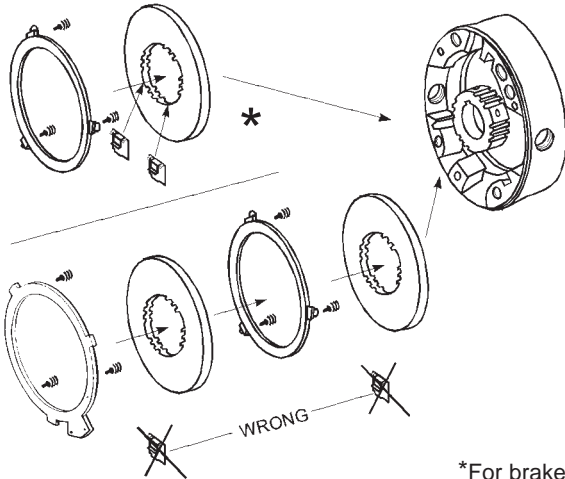

- 4A**

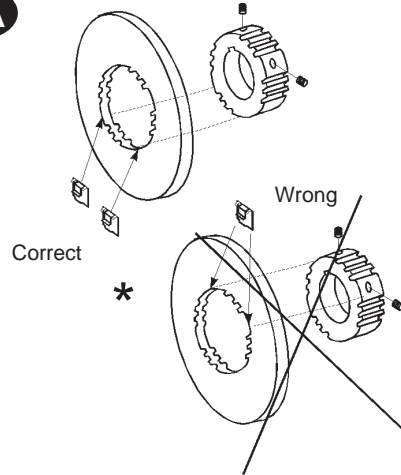

* Stabilizer springs are for use on single disc units only. Position springs opposite set screw holes.

*For brakes with vertical springs, see page 5.

- 5** Reposition support plate on endplate and tighten mounting screws to 55 lb-in.

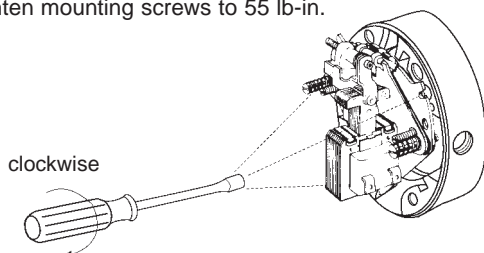

- 6** Reposition housing and tighten nuts to 12 lb-in.

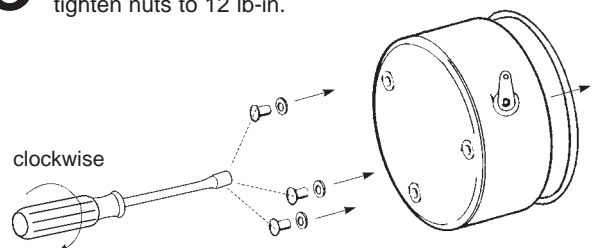

COIL REPLACEMENT

Series 56,800

1 Remove brake housing.

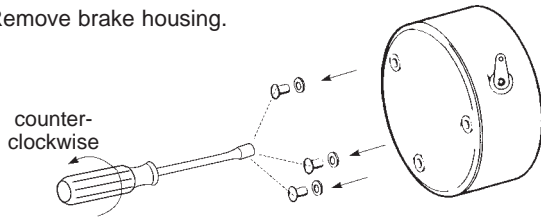

2 Disconnect coil leadwires from power source.

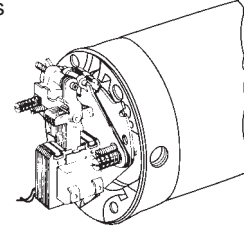

3 Insert screwdriver between support plate and lever arm and pry forward.

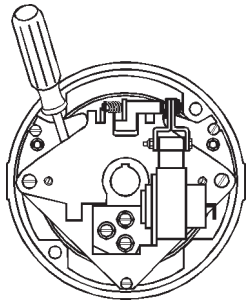

4 Lift plunger/solenoid lever assembly out of coil.

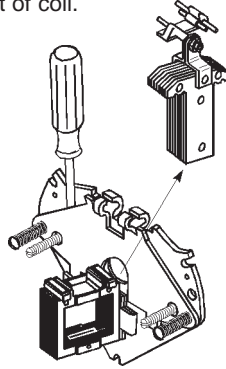

5 Remove plunger guide.

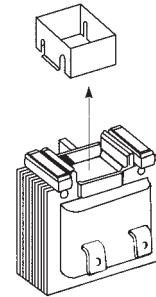

6 Discard coil.

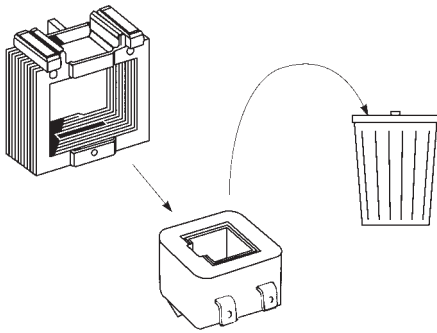

7 A) Insert new coil. (Lead wires in same position as old coil.)
B) Insert plunger guide.

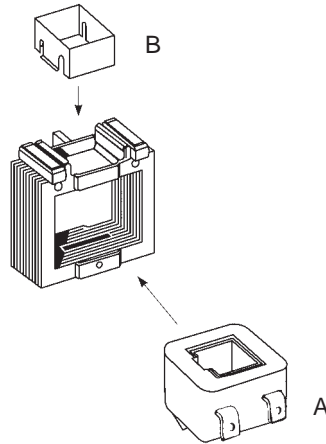

8 A) Reinsert plunger into coil; drop pivot pin into cradle of support plate.
B) Remove screwdriver.

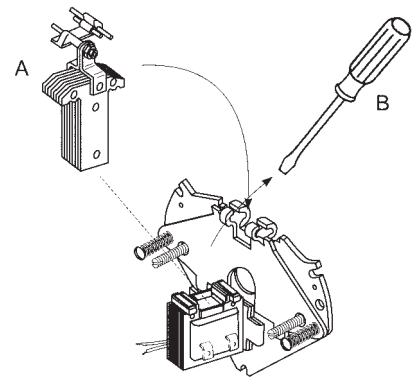

9 Reconnect coil leadwires to power source.

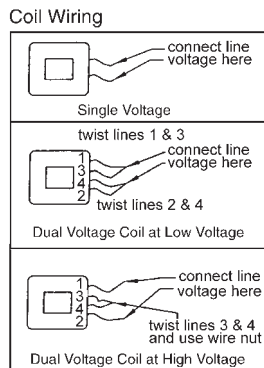

10 Reassemble housing. Tighten to 12 lb-in.

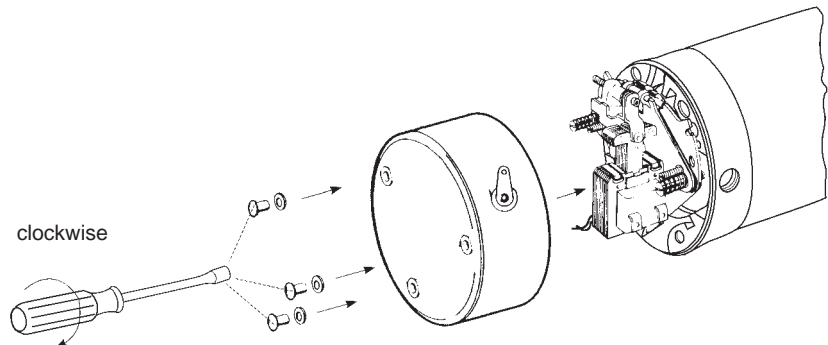

Vertical Brake Assembly

Single disc brakes (1.5, 3 & 6 lb-ft) are universal mount and do not require separator springs. Double disc brakes (10 & 15 lb-ft.) universal mount but require separator springs which are preassembled to the stationary disc. These discs are inserted spring first into the brake. Refer to figure 5A below.

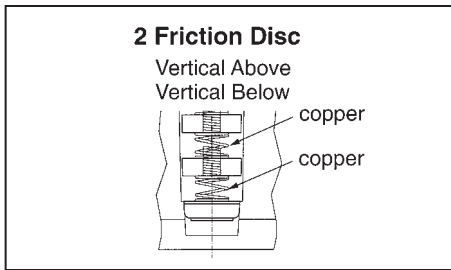

Figure 5A

Installation Procedure for 20 and 25 lb-ft brakes if mounted vertical to motor shaft (These brakes are factory assembled for horizontal operation.)

Remove support plate by loosening the three mounting screws.

Remove stationary discs and friction discs.

Using the spring kit provided with this brake, insert three springs of identical color into each stationary disc hole. Springs are inserted from the side opposite the indent mark (see Figure 5B). Stationary disc should be placed on a clean flat surface with a clearance hole to allow the tip of the spring to extend through the bottom side of the stationary disc. Using the 1/8" pin provided and a hammer, drive the hold until the large coil diameter bottoms out against the disc.

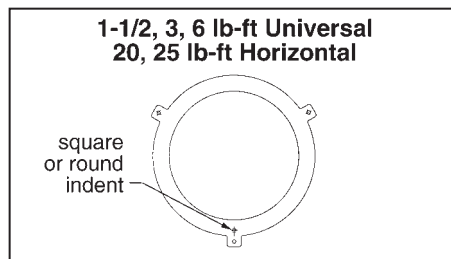

Figure 5B

Reassemble the disc pack with the stationary discs in the proper arrangement shown in Figure 5C. Mount support plate and torque screws evenly to 55 in-lbs.

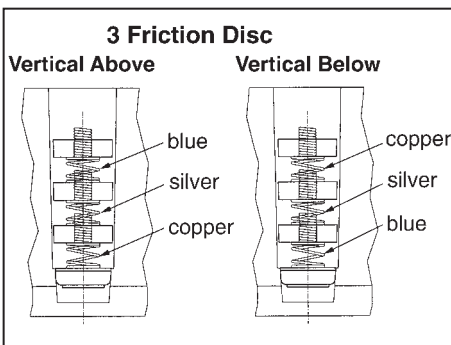

Figure 5C

Torque Adjustment

Brake is factory set for nominal rated static torque which is maximum torque. Torque may be decreased up to 50% for increased stopping times up to 2 second stop time.

The torque on the 1-1/2 lb-ft brake may not be reduced.

Turn both adjustment nuts (11), Figure 6, equal amounts counterclockwise to decrease torque. See Table A for torque reduction permissible amounts.

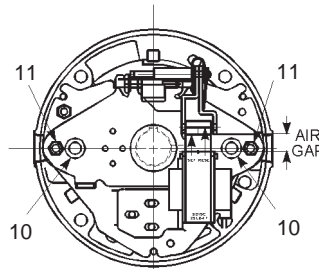

Figure 6

TABLE A

Nominal Static Torque (lb-ft)	Original Spring Height (inches)	Maximum Counterclockwise Turns	% Torque Reduction per Turn
1-1/2	1.69	-	-
3	1.47	5-1/2	9%
6	1.47		
10	1.53		
15	1.53		
20	1.53		
25	1.47		

General Maintenance

Warning! Any mechanism or load held in position by the brake should be secured to prevent possible injury to personnel or damage to equipment before any disassembly of the brake is attempted or before the manual release knob is operated on the brake.

Observe all cautions listed at the beginning of this manual before attempting to service brake.

Troubleshooting

A. If brake does not stop properly or overheats, check the following:

1. Are friction discs excessively worn, charred, or broken?
2. Hub may have become loose and shifted on shaft. Recheck set screw torque. Reposition hub if shifted.
3. With brake de-energized and housing (7) removed, check compressed length of pressure springs (11). Compare to Table values (at right) and adjust to minimum height to obtain desired stop times.
4. Is solenoid air gap adjusted correctly? See Page 3 for instructions.
5. Solenoid may not be energizing and releasing the brake. Check voltage at the coil and compare to the coil and/or nameplate voltage rating.
6. Check linkage for binding. Depress solenoid plunger down to frame surface. Movement to be without binding.
7. Brake coil should be energized at same time or prior to energization of motor, and de-energized at same time or after de-energization of motor.
8. Replace friction disc(s) when worn area is one half of original thickness.
9. Check to be sure wear adjust screws are of equal height. Measure from inboard side of support plate with depth micrometer. Turn one screw to obtain equal height.

B. If solenoid hums, pulls in slowly, or coil burns out, check the following:

1. Solenoid plunger to frame contact surface may be excessively dented.
2. Are solenoid plunger to frame contact surfaces sticky and dirty.
3. Solenoid mounting screws may have become loose, causing frame to shift and plunger to seat improperly.

WARNING
The thermal protector TSW2 (21A) mounted in this brake must be wired into control circuit to limit the brake internal surface temperature.

TSW2 will open motor circuit and cause brake to engage. In extremely moist atmospheres a heater is recommended and should remain energized continually.

TYPICAL CONNECTION DIAGRAM

Rating TSW2

125 VA
Hi-pot Test
Voltage 1250 Maximum

For information on dynamic torque and calculation of thermal capacity in use, refer to Application Engineering Section of Catalog 200 (Stearns Spring-Set Disc Brakes.)

Figure 7

Information required when ordering replacement parts:

- Give Part Number of parts or kits needed, Brake Model Number, and Brake Serial Number. The Brake Model and Serial Number may identify special brakes not covered by this parts list.
- When ordering hubs, specify shaft diameter (hub bore) and keyway.

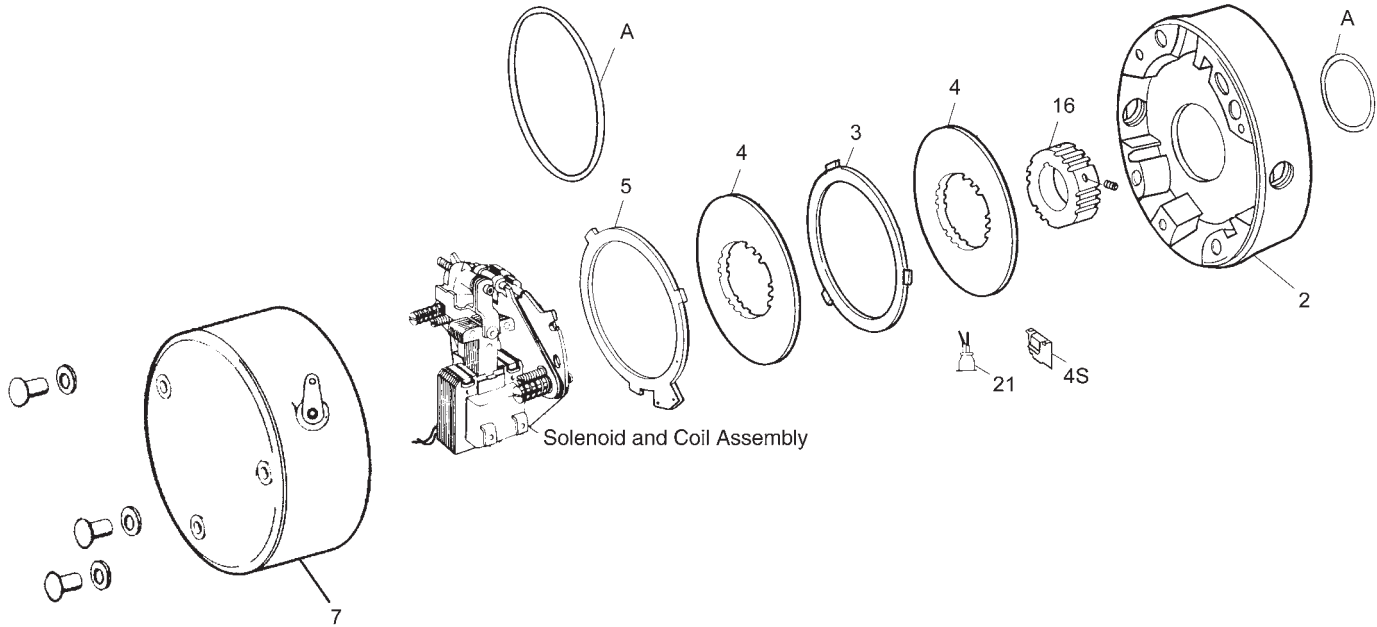
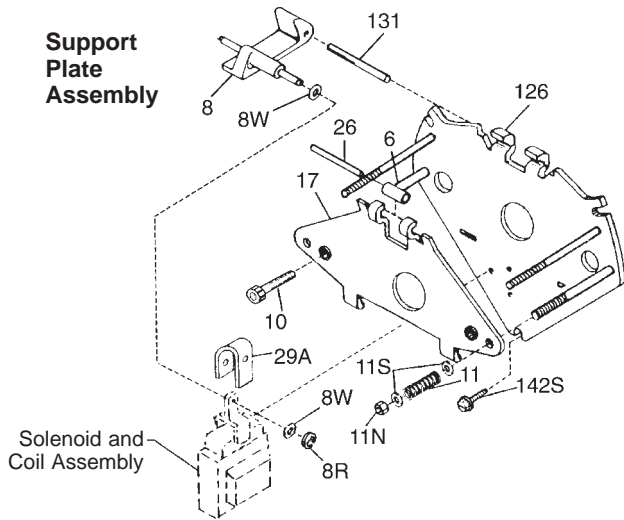

TABLE 1
Components of Standard Brake

Item	Description	Part Number ↓	Torque (lb-ft)	1.5 and 3	6	10	15	20 and 25
			Brake Model Number →	1-056-802-00 & 812-00	1-056-822-00	1-056-832-00	1-056-842-00	1-056-852-00 & 862-00
A	Hardware Kit - side release	5-66-1015-00	1	1	1	1	1	1
<i>Not shown</i>	Plug/Gasket kit - NEMA 4 Plug/Gasket kit - NEMA 4 (3 disc)	5-63-0532-00 5-63-0534-00	1	1	1	1		1
7	Housing - side release	5-07-5050-00	1	1	1	1	1	1
5	Pressure plate (universal mount)	8-003-515-00	1	1	1	1	1	1
3	Stationary disc kit (universal mount)	5-66-8354-00			1	1	2	
<i>Not shown</i>	Vertical spring kit	5-63-0525-00						1
4	Friction disc kit Stabilizing spring (part of friction disc kit)	5-66-8462-00	1 2	1 2	2 *	2 *	3 *	
21	Thermostat	9-62-8026-00	1	1	1	1	1	1
16	Hub and set screw assembly (1 disc)	5/8 bore	5-16-5151-00-01B	1	1			
		7/8 bore	5-16-5151-00-01D	1	1			
		1-1/8 bore	5-16-5151-00-01E	1	1			
	Hub and set screw assembly (2 & 3 disc)	5/8 bore	5-16-5153-00-01B			1	1	1
		7/8 bore	5-16-5153-00-01D			1	1	1
		1-1/8 bore	5-16-5153-00-01E			1	1	1
2	Endplate & seal assembly	1 disc	5-02-5049-00	1	1			
		2 & 3 disc	5-02-5050-00			1	1	1

* Certain multiple friction disc model numbers require a single stabilizer clip (4S) added to each friction disc. If your brake has these clips, they must be replaced when the friction disc is replaced. This clip is included as part of the friction disc kit 5-66-8462-00.



Solenoid and Coil Assembly

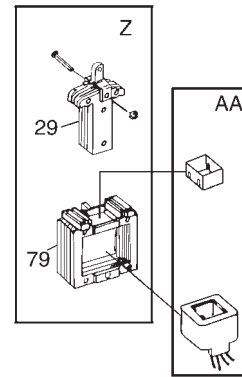

TABLE 2
Contents of Support Plate and Coil Assembly

Item	Description	Part Number ↓	Torque (lb-ft)				
			1.5 & 3	6 & 10	15 & 20	25	
Support Plate Assembly (items 6 through 131) →							
6	Bearing	8-006-501-00	1	1	1	1	
8	Solenoid lever	8-008-504-01	1	1	1	1	
8R	Retaining ring	9-03-0057-00	1	1	1	1	
8W	Spacer	9-45-0168-00	2	2	2	2	
11N	Torque adjustment nut	9-40-3928-00	2	2	2	2	
10	Wear adjustment screw	9-17-8420-00	2	2	2	2	
11	Pressure spring	9-70-1215-00	2				
	Pressure spring	9-70-1523-00		2			
	Pressure spring	9-70-1524-00			2	2	
11S	Spring washer	9-46-0010-00		4	4	4	
17	Lever arm and stop nut assembly	5-17-5011-00	1	1	1	1	
26	Bearing pin	9-29-4826-00	1	1	1	1	
29A	Plunger stop	8-094-503-00	1	1	1	1	
126	Support plate and spring stud assembly (3 housing studs)	5-26-5020-00	1	1	1	1	
131	Pivot pin	9-29-4836-00	1	1	1	1	
142S	Mounting screws	9-25-9013-00	3	3	3	3	
Z	No. 4 Solenoid kit	5-66-5047-00	1	1	1	1	
12A	No. 4 coil kit 60 Hz	115/230 Vac	5-96-6407-05	1			
		230/460 Vac	5-96-6409-05	1			
		115 Vac	5-96-6401-05	1			
		230 Vac	5-96-6402-05	1			
		460 Vac	5-96-6404-05	1			
		575 Vac	5-96-6405-05	1			
	No. K4 coil kit 60 Hz	115/230 Vac	5-96-6457-05		1		
		230/460 Vac	5-96-6459-05		1		
		115 Vac	5-96-6451-05		1		
		230 Vac	5-96-6452-05		1		
		460 Vac	5-96-6454-05		1		
		575 Vac	5-96-6455-05		1		
	No. K4+ coil kit 60 Hz	115/230 Vac	5-96-6407-25			1	
		230/460 Vac	5-96-6409-25			1	
		115 Vac	5-96-6401-25			1	
		230 Vac	5-96-6402-25			1	
		460 Vac	5-96-6404-25			1	
		575 Vac	5-96-6405-25			1	
	No. M4+ coil kit 60 Hz	115/230 Vac	5-96-6457-25				1
		230/460 Vac	5-96-6459-25				1
115 Vac		5-96-6451-25				1	
230 Vac		5-96-6452-25				1	
460 Vac		5-96-6454-25				1	
575 Vac		5-96-6455-25				1	

TABLE 3
Contents of Kits and Assemblies

Item	Kit Description
A	Hardware kit – NEMA 4 (5-66-101X-00) 1 – Endplate oil seal 1 – Drain plug 3 – Housing nuts 3 – Housing nut seal washers 2 – Endplate conduit pipe plugs 1 – Housing-to-endplate gasket
3	Stationary disc kit (5-66-8354-00) 1 – Stationary disc
4	Friction disc kit (5-66-8462-00) 1 – Friction disc 2 – Stabilizing springs
16	Hub and screw assembly – all types, all bores (5-16-515X-00) 1 – Brake hub 2 – Set screws
Z	No. 4 solenoid kit (5-66-5047-00) 1 – Plunger 1 – Solenoid link 1 – Frame (including mounting bracket) 1 – Solenoid link cap screw 1 – Solenoid link nut 3 – Solenoid mounting screws
12A	No. 4 AC coil kit (5-96-64XX-X5) and Coil / Top Plunger guide / Wire nut

[BACK TO PRODUCT PAGE](#)



Rexnord Industries, LLC
Stearns Division
5150 S. International Drive
Cudahy, Wisconsin 53110
(414) 272-1100 Fax: (414) 277-4364 www.stearns.rexnord.com

M1 Electrical Release Indicator Switch

This switch is used to indicate when the brake is in a released, non-holding position. This mechanism utilizes a mechanical limit switch.

Series	List Price Adder
56,X00 & 65,300	\$450.00
81,000; 82,000; 87,X00	450.00
86,X00	900.00

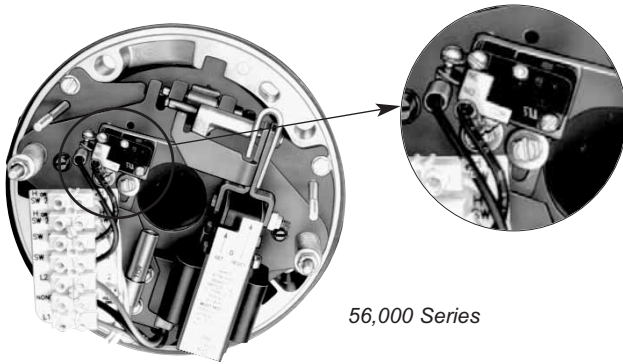

56,000 Series

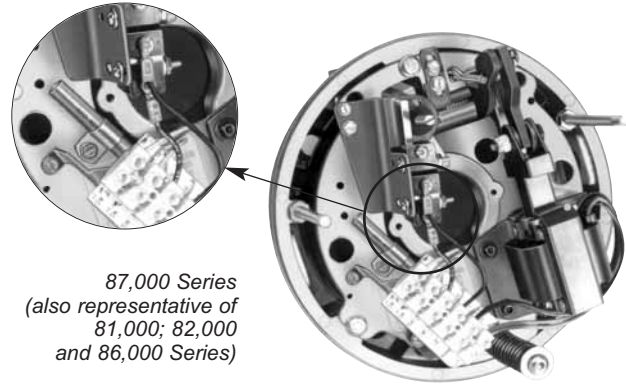

87,000 Series
(also representative of
81,000; 82,000
and 86,000 Series)

Not available on 56,800 or 87,800 Series Brakes.

M2 Electrical Release Indicator Proximity Switch

Same function as the switch in M1 above; except, M2 uses an electronic proximity sensor.

Series	List Price Adder
81,000 82,000 87,X00	\$1375.00
86,X00	2750.00

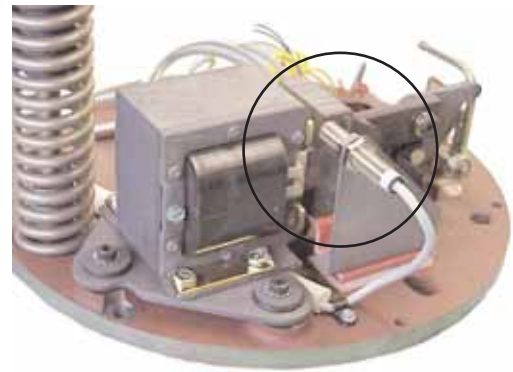

Not available on 56,800 or 87,800 Series Brakes.

M3 Brass Pressure Plate

Typically used in marine applications or in applications where the potential for sparks need to be eliminated. Brass can also be used to reduce torque.

Series	List Price Adder
56,X00	See M4
65,X00	\$250.00
81,000; 82,000	800.00
86,X00	1050.00
87,X00	600.00



M4 Brass Stationary Discs

Used with brass pressure plate (List per disc).

Series	List Price Adder
56,X00	\$250.00
65,X00	250.00
87,X00	450.00
81,000; 82,000	600.00
86,X00	750.00

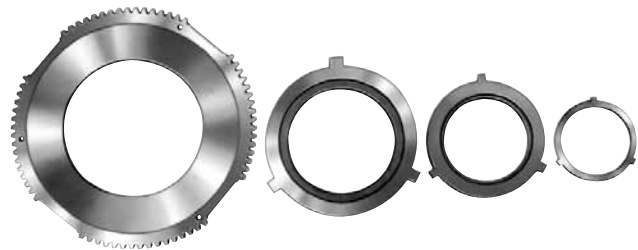

M5 Breather Drain

A drain plug is tapped into the bottom of the housing to let moisture escape. This option is only available on brakes with cast aluminum or cast iron housings.

Series	List Price Adder
56,X00	\$380.00
65,X00	500.00
81,000 82,000 86,X00 87,X00	380.00



M6 Class H Insulation

Brake is provided with an epoxy encapsulated coil, rated for NEMA Class H designation.

These Class H coils are standard on hazardous location brakes.

Series	List Price Adder
56,X00	\$145.00
87,X00	175.00
81,000 82,000	285.00
86,X00	570.00



M7 Housing Machining for Encoder/Tach Mounting

Series	Standard Machining ¹				Close Tolerance ²			Tether Mount ³	
	Bolt Circle & Register		Bolt Circle - but no Register		Bolt Circle & Register			A Single Bolt Hole	
	Open ⁴ Enclosure List Price Adder	Enclosed ⁵ List Price Adder	Open ⁴ Enclosure List Price Adder	Enclosed ⁵ List Price Adder	Open ⁴ Enclosure List Price Adder	Enclosed ⁵ List Price Adder	Maximum Thru-Shaft Dia. (inch)	Open ⁴ Enclosure List Price Adder	Enclosed ⁵ List Price Adder
56,X00 (except N/A for 56,800)	N/A	N/A	N/A	N/A	N/A	N/A		\$350	\$460
87,000 - 87,100	\$700	\$1,200	\$80	\$350	\$2,450	\$2,750	1.63	\$240	\$350
87,M00 - 87,500 - 87,600	N/A	\$1,200	N/A	\$350	N/A	\$2,750		N/A	\$350
81,000 - 82,000 ⁶	\$1,100	\$1,375	\$305	\$580	\$2,550	\$2,825	2.5	\$465	\$740
86,000	\$1,100	\$1,375	\$380	\$780	\$2,550	\$2,950		\$540	\$940

¹**Standard Machining:** The housing is machined for a thru shaft, and to allow for an encoder or tach to be mounted. This option is only available on brakes with cast aluminum or cast iron housings. Consult factory for availability.

²**Close tolerance:** The housing and endplate are assembled and dowel pinned together - then machined as a matched set for a through shaft and encoder mounting. This option is only available on brakes with cast aluminum or cast iron housings. This option is recommended for Series 81,000; 82,000; and 86,X00 due to the long distance between the motor and encoder.

³**Tether Mount:** The housing is machined for a through shaft, and a single tapped hole for a bolt to secure a tether arm. (56,X has a through hole and tach-welded nut on inside of housing, instead of a tapped hole).

⁴Referred to on the product pages in the catalog as IP23

⁵Referred to on the product pages as IP54/55 (these enclosure ratings no longer apply when the housing is machined for this modification - the customer is responsible for meeting any specific enclosure rating when assembling the encoder).

⁶M7 Modification for Series 81,000 and 82,000 will also require the M12 Modification; the side manual release.



M8 Conduit Box with Terminal Strip

A terminal strip is located inside the conduit box. It allows for easy connection and identification of lead wires.

Series	List Price Adder
All series except hazardous location (not available for the 48,100 series)	\$300.00 (IP 23) \$600.00 (IP 54)
All hazardous location brakes	\$600.00



M9 DC Coil Option

For DC voltage applications. Operates with an electronic DC switch module.

Series	List Price Adder	Additional Adder for Non-Standard Voltage
56,X00	\$ 300.00	\$ 250.00
87,X00	570.00	250.00
81,000	1050.00	250.00
82,000	1565.00	250.00
86,X00	2625.00	500.00

For standard voltage listing, see the ordering information section for the specific brake.

Not available on Hazardous Location Brakes.

M10 Nameplates

To order new brake nameplates, the serial number of the brake is required. A loose nameplate shipped from Stearns Division without being attached to a brake must have all agency markings removed (UL, CSA, etc.). In order to have a brake renamed with the appropriate agency markings, it must be returned to Stearns Division for product verification.

List Price:	First Nameplate	\$150.00
Net Price:	Additional Mylar Nameplates	1.50
	Additional Metal Nameplates	4.00

M11 Nonstandard Hub or Keyway

For standard bore diameter and keyway specifications, see specific brake selection page. For taper bores, consult factory for pricing.

Description	List Price Adder					
	48,100	56,X00	65,X00	81,000 82,000 86,000	87,000 87,100 87,800	87,700
All Quantities and Enclosures	\$225.00	225.00	325.00	600.00	250.00	250.00

M12 Side Manual Release

Side release not available on the 1-086-000

Sheet Metal Housing (IP 23 Only)	List Price Adder
56,000; 56,400; 56,500	\$50.00
87,000; 87,100	\$50.00
Cast Iron Housing	List Price Adder
87,000 IP 23	\$385.00 includes cast iron housing adder of \$110
87,000 IP 54	\$275.00
81,000 82,000	\$350.00



M13 Space Heater (115 or 230 Volt Only)

A space heater cartridge is used to prevent moisture build-up inside the brake housing.

Series	Wattage	List Price Adder
56,X00*	15	\$210.00
81,000; 82,000; 86,X00	50 and 75	275.00
87,X00*	25 to 30	225.00
Hazardous Duty Brakes	25 to 50	750.00

*Not available on 56,800 or 87,800 Series Brakes



56,000 Series



87,000 Series (also representative of 81,000; 82,000 & 86,000 Series)

M14 Special Paint

Based on a zinc chromate finish, both inside and outside of brake. Consult factory for actual application.

Series	List Price Adder
56,X00	\$210.00
65,X00	300.00
81,000, 82,000, 86,X00	550.00
87,000	525.00



M15 Stainless Steel Self-Adjust Mechanism

For severe duty applications. This option includes a stainless steel pinion and plated wrap spring in the auto-adjust mechanism. It is only available on the 81,000; 82,000; 86,000 and 87,000 Series Brakes

Series	List Price Adder
81,000; 82,000; 87,000	\$350.00
86,X00	\$700.00



self-adjust mechanism

M16 Stainless Steel Hardware

All external hardware is provided in stainless steel.

Series	List Price Adder
48,100	\$125.00
56,X00, 87,X00	\$150.00
81,000, 82,000 86,000	\$275.00

M17 Terminal Strip

A terminal strip is located in the inside of the brake, on the support plate. It allows for easy connection and identification of lead wires.

Series	List Price Adder
ALL	\$150.00

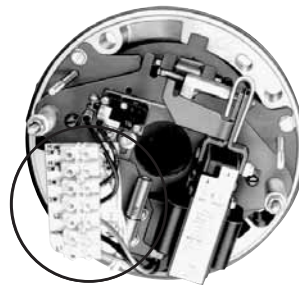

56,000 Series

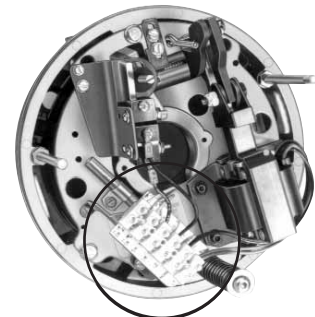

87,000 Series (also representative of 81,000; 82,000 & 86,000 Series)

M18 Thermostat (thermal switch)

This switch is used to indicate when a brake is overheating. Thermostats are standard in 8X,300 and 65,X00 Series. This option is for NON-UL brakes only.

Series	Switch Operation Specifications	List Price Adder
87,X00	Normally Closed: Opens at 295°F, Closes at 255°F	\$400.00
81,000, 82,000 86,X00	Normally Closed: Opens at 210°F, Closes at 180°F	400.00
56,X00	Normally Closed: Opens at 195°F, Closes at 175°F	400.00



M19 Through-Shaft Enclosure

This configuration allows for the motor shaft to extend beyond the housing of the brake.

Series	List Price Adder
56,000, 56,400	N/C
56,100, 56,200	\$110.00
56,600	110.00
81,000, 82,000	225.00
86,000	300.00
87,000, 87,100 sheet metal	N/C*
87,000, 87,100 with cast iron housing	225.00 (adder for cast iron housing is \$210.00 additional)



*Up to 1-5/16".
Above 1-5/16", add \$80.00.

M20 Through-Shaft Cast Iron Enclosure with Lip Seal

This configuration allows the motor shaft to extend beyond the housing of the brake with a bushing to use with a housing lip seal.

Series	List Price Adder
56,100, 56,200 56,600	\$220.00
81,000, 82,000	500.00
86,000	700.00
87,000, 87,100	300.00



M21 Vertical Mounting for 56,000 Series & 65,300 Series

The 56,000 20 and 25 lb-ft Series Brakes are shipped with spring kits. Vertical modification at 15° from horizontal. Read installation and service instructions for details on its use.

Description	List Price Adder
Factory assembly for three disc configuration.	\$20.00

3 Friction Disc Brake

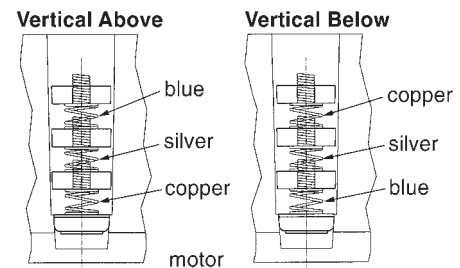

Example of 56,000 Series spring requirements for vertical above and below mounting.

M23 Vertical Mounting for 87,X00 Series

For factory modification to vertical above or below application. Vertical modification at 15° from horizontal.

Series 87,000 & 87,100

Torque Value (lb-ft)	IP 23 & IP 54 steel hsg Above	IP 23 & IP 54 steel hsg Below	IP 54/55 cast iron Above	IP 54/55 cast iron Below
6, 10, 15, 25 & 35	\$95.00	no mod req'd	\$370.00*	no mod req'd
50 & 75	\$105.00	\$105.00	\$380.00*	\$105.00
105	\$135.00	\$135.00	\$410.00*	\$135.00

*Includes adder for side manual release

Series 87,300; 87,800; 87,700

Torque Value (lb-ft)	Vertical Above	Vertical Below
6, 10, 15, 25 & 35	\$95.00	no mod req'd
50 & 75	\$105.00	\$105.00
105	\$135.00	\$135.00

3 Friction Disc Brake

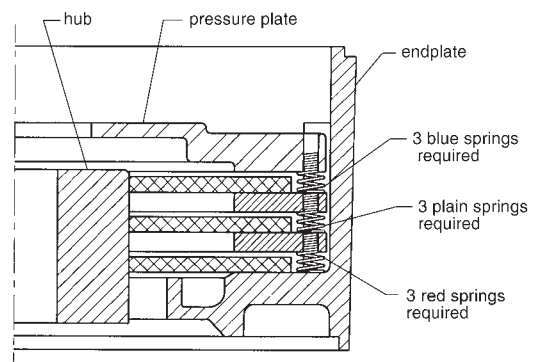

Example of 87,000 Series spring requirements for vertical above mounting.

M24 Vertical Mounting for 81,000; 82,000 and 86,000 Series

These brakes require factory modifications for vertical applications. Vertical modification at 15° from horizontal.

Series	Torque Value (lb-ft)	IP 23 Above & Below	IP 54 Above	IP 54 Below
81,000 & 82,X00	125 & 175	\$250.00	\$575.00*	\$250.00
81,000 & 82,X00	230	300.00	650.00*	300.00
82,X00	330	300.00	650.00*	300.00
82,X00	440	500.00	850.00*	500.00
86,000	500 & 750	750.00	750.00*	750.00

*Includes adder for side manual release

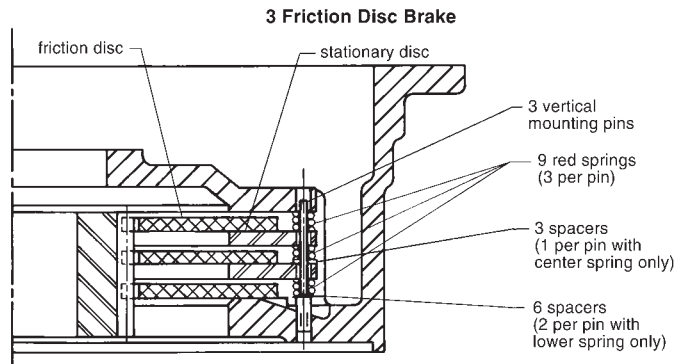

Example of 81,000 Series pin, spring and spacer requirements for vertical above mounting.

M25 Voltage Non-Standard (AC)

For standard voltage listing, see the ordering information section for the specific brake.

Series	List Price Adder
48,100	\$165.00
65,X00	165.00
56,000	165.00
81,000; 82,X00	200.00
86,X00	400.00
87,X00	175.00

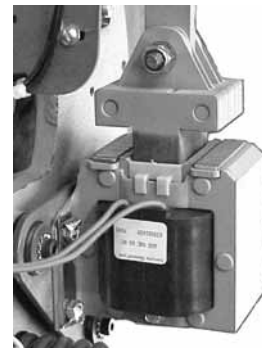

M27 Wear Indicator (Friction Disc) Switch with Leads

A mechanical switch is installed to indicate when the friction disc requires replacement.

Series	List Price Adder
81,000; 82,X00	\$225.00
86,000	225.00
87,X00*	225.00

*N/A on 87,800

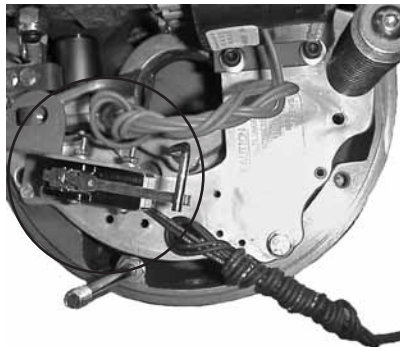

87,000 Assembly

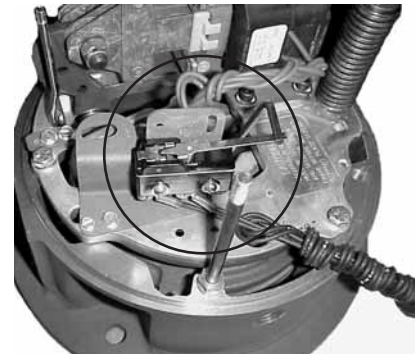

87,000 Assembly

M29 Special Shaft-Coupler Brake and Foot Mount Brake

Any non-standard input or output shaft on a 56,700, 87,200 or 87,700 Series Brake.

Series	List Price Adder
56,700	\$325.00
87,200; 87,700	325.00



M30 Taper-Lock Hubs

For use in severe duty applications and reversing application to secure the brake hub to the motor shaft.

Series	Series	List Price Adder
87,000; 87,100 IP 23 only	10 to 35 lb-ft	\$200.00
	50 to 75 lb-ft	225.00
	105 lb-ft	250.00
81,000	125 & 175 lb-ft	225.00
	230 lb-ft	325.00
82,000	125 & 175 lb-ft	375.00
	230 & 330 lb-ft	550.00
	440 lb-ft	675.00



M31 Special Length Lead Wires

Up to 5'	Series	List Price Adder
	All	\$65.00

Over 5'	Series	List Price Adder
	All	\$130.00

M32 Non-Maintained (Deadman) Manual Release

The brake is mechanically released while the release is pulled into a release position. Once released, the brake sets.

Series*	List Price Adder
56,200, 56,700, 56,800 & 56,900	\$110.00
56,000, 56,400 & 56,500	185.00
81,000; 82,000 & 87,000	125.00
86,000	250.00

*N/A on 56,300.
Standard on 56,100 and 56,600.



M33 Metric Machining Including Cast Iron Endplate

Stearns SAB's can be used with metric motor frames. The following table indicates standard frame capabilities for an IEC B14 Face mount.

Series	IEC Frame Sizes	List Price Adder
56,200; 56,400; 56,600 & 56,900	B14 flange in sizes 80; 90 & 100 B5 flange in sizes D63 & D71	\$340.00
56,500	B14 flange in sizes 112; 132 & 160 B5 flange in sizes D71; D80; D90; D100 & D112	\$340.00
87,000	B14 flange in sizes 112; 132 & 160 B5 flange in sizes D71; D80; D90; D100 & D112	\$340.00

M34 Derating of Torque

Stearns industrial SAB's can be custom built to meet your specific torque requirements.

Series	List Price Adder	Derate To
56,500	\$315.00	6 lb-ft
87,100	315.00	20 or 30 lb-ft
81,000 & 82,000	460.00	To be approved with application engineering

M35 Special Internal Lead Wire Hole with Bushing

Any non-standard, internal lead wire hole in the endplate.

Series	List Price Adder
All brakes except hazardous location brakes	\$175.00



M36 Housing Split

SAB's can be provided with a split housing.

Series	List Price Adder
81,000; 82,000 & 86,000	\$725.00
81,000; 82,000 & 86,000 gasketed	\$1,000.00
87,000; 87,100 sheet metal	\$200.00
87,000; 87,100 cast iron gasketed	\$250.00



M37 Internal Release

An internal manual release requires that the housing be removed before the brake can be released by hand.

**N/A for hazardous location brakes*

Series	List Price Adder
87,0XX; 81,0XX; 82,0XX; 86,0XX	N/C

M38 Motor Gasket

The brake is provided with an additional C-Face gasket to be placed between the brake and motor.

Series*	List Price Adder
81,000; 82,000; 86,000	\$100.00
56,X00 & 87,000	75.00

**N/A for hazardous location brakes*

M39 Corrosion-Resistant Endplate

Rust preventative treatment applied to brake endplate.

Series	List Price Adder
56,200, 56,400, 56,500, 56,800 & 65,300	\$425.00
81,000; 82,X00 & 86,000	575.00
87,X00	475.00



M40 Special Milling: Flat Bottom on Housing & Endplate

This modification is provided in the event the flange between the endplate and housing interfere with the mounting configuration.

Series	List Price Adder
81,000; 82,000 & 86,000	\$650.00



M41 Brass Nameplate with Special Engraving

Brass nameplates offer greater durability in outdoor applications.

Series	List Price Adder
81,000; 82,000 & 86,000	\$75.00

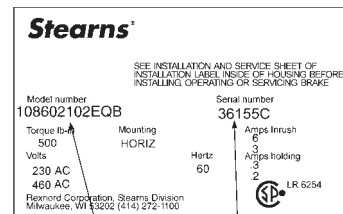

MODEL NUMBER will appear on brake nameplate.

SERIAL NUMBER

M42 Stainless Splined Hub

Stainless steel splined hubs are available for extreme outdoor applications, to prevent corrosion on the disc and hub interface.

Series	List Price Adder
81,000; 82,000 & 86,000	\$1060.00
87,000	800.00



M43 Viton® Gasket

Gaskets and o-rings in brakes can be provided in Viton® (fluorocarbon) material, in place of the standard neoprene. However, the V-wiper steel-backed seals that are used on pull rod manual releases are not available in Viton® and remain as neoprene.

Viton® is a registered trademark name of DuPont.

Series	List Price Adder
81,000; 82,000; 86,000	\$1,060.00
87,000*	\$1,125.00
56,000	\$950.00

*Viton® gaskets and o-rings are standard for 87,X00 series, except for hazardous location brakes where Viton® seals are N/A.

**Except series 56,200; 56,700; & 56,900 - where Viton gaskets are standard.

M44 Special Friction Disc (per Disc)

Any non-standard friction disc in a brake.
Cost is per disc.

Non-standard discs include: hi-inertia friction discs and heavy duty friction discs. Does not include carrier ring friction discs (see M46 and M47).

Series	List Price Adder
87,000	\$50.00
56,000	45.00



M45 Splined Hub and Friction Disc

Standard on most models. Used for severe duty and reversing applications.

Series	List Price Adder
87,300	No Charge

Series	Torque (lb-ft)	List Price Adder
87,X00*	6-35 lb-ft	190.00
	50 & 75 lb-ft	290.00
	105 lb-ft	390.00

* Spline is standard on this series.
Adder is for pre-revision 24-tooth spline.

M46 Carrier Ring Friction Disc

The friction material is bonded to a steel or zinc/aluminum alloy ring. This is used for severe duty applications and applications where people are being moved.

Series	Carrier ring material	List Price Adder (per disc)
Horizontal Use Only		
56,X00* (not available on 56,800 series)	Aluminum	\$420.00
81,000	Steel	700.00
82,000	Steel	700.00
Horizontal or Vertical Use		
87,X00** (not available on 87,300 or 87,800 series)	Zinc aluminum alloy	550.00



M47 Carrier Ring Friction Disc (Bronze)

The friction material is bonded to a bronze ring. This is used for severe duty applications and applications where people are being moved.

Horizontal applications only

** Only available with pre-revision design, 24-tooth splined hub, which is included in this price

Series	List Price Adder (per disc)	
81,000	N/A	
82,000	\$1050.00	
86,000	1250.00	
87,X00**	6-35 lb-ft	925.00
	50 & 75 lb-ft	1850.00
	105 lb-ft	2775.00



M48 1,08X,000 Series Manual Adjust Mechanism

Excellent for holding applications when disc wear is not a concern. (Not available on hazardous location brakes.)

Series	List Price Adder
87,000	Subtract \$50 List
81,000 82,000 86,000	No Charge

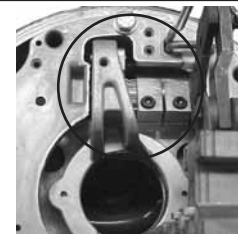

M60 Encoders

Internally mounted encoders are available in some series brakes, including some hazardous location brakes. See pages 49-50 for series availability and additional information.

Maximum Encoder Diameter (in.)	
1-056	N/A
1-087-E00	2.0"
1-081 & 1-082	2.5"
1-086	3.5"

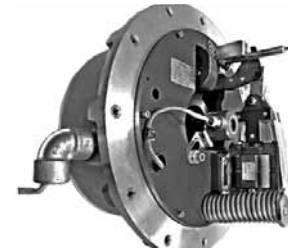

Technical Data

SAB Motor Frame Adapter Dimensions

Selection

To select an adapter for a specific brake, refer to the *Motor Frame Adapter Tables* as shown in the brake series sections of this Catalog. After selecting the adapter stock number, refer to the Tables below for dimensions.

All adapters are constructed with an opening for internal lead wire connection, corresponding to the NEMA standard location for the motor frame size.

Screws for mounting adapter to motor must be provided by customer. Socket head cap screws are supplied for mounting brake to adapter.

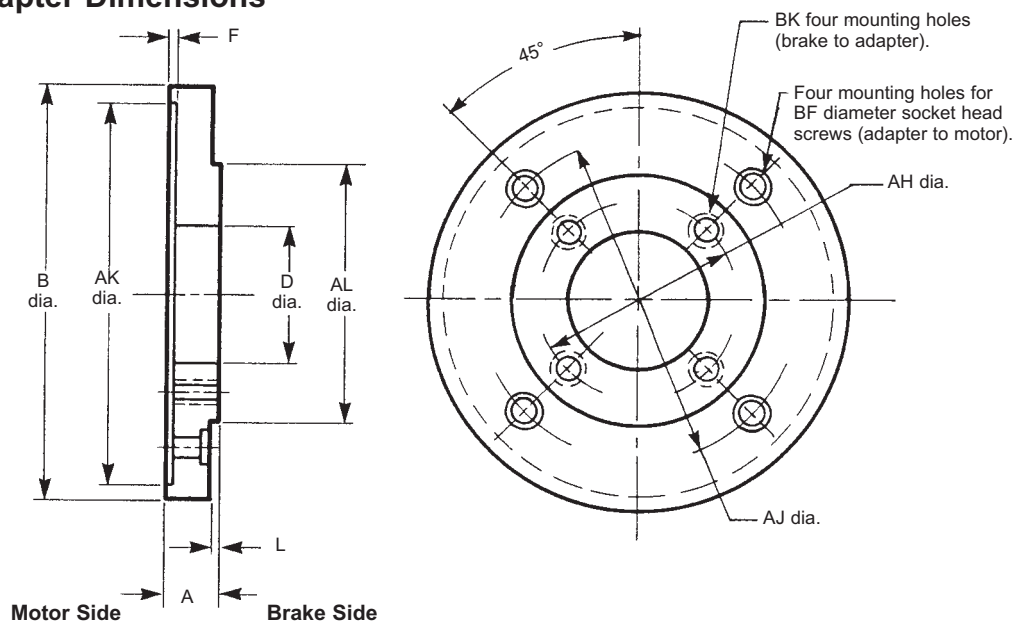

Dimensions for estimating only. For installation purposes, request certified prints.

Brake Series	Torque (lb-ft)	Adapter Stock Number	Dimensions in Inches (Dimensions in Millimeters)											Add'l Shaft Length Req'd	List Price	Discount Symbol			
			A	AH	AJ	AK	AL	B	BF	BK Hole	D	F	L						
56,000	1.5 - 6	5-55-5041-00				8.500 (215.900)	4.497 (114.325)											\$700	B4
65,300*		5-55-5046-00	1.25 (31.75)	5.88 (149.22)	7.25 (184.15)	8.502 (215.900)	4.500 (114.325)	9.00 (228.60)	.50 (12.70)	3/8 - 16 x 1/2 deep	4.00 (101.60)	.19 (4.76)	.12 (3.18)	.94 (23.88)				\$700	B4
56,000 and 56,800*	10 - 25	5-55-5043-00																	
87,000 and 87,800*	6 - 105	5-55-7046-00	1.06 (26.99)		11.00 (279.40)	12.501 (317.525)	8.499 (215.875)	13.00 (330.20)	.62 (15.88)		4.12 (104.78)			.87 (22.10)			\$875	B2	
87,300		5-55-7054-00		7.25 (184.15)		12.504 (317.602)	8.497 (215.849)					.19 (4.76)		.38 (9.52)				\$875	B2
87,000 and 87,800*	6 - 105	5-55-7055-00	1.00 (25.40)		9.00 (228.60)	10.500 (266.700)	8.499 (215.875)	11.00 (279.40)	**		6.25 (158.75)			.81 (20.57)			\$450	B2	
87,300*		5-55-7045-00				10.502 (266.751)	8.497 (215.849)						.25 (6.35)	.25 (6.35)				\$450	B2
87,000, 87,800* and 87,300*	6 - 105	5-55-7043-00	.75 (19.05)	7.25 (184.15)	5.88 (149.35)	4.502 (114.35)	8.499 (215.875)	8.75 (222.25)	.62 (15.75)	1/2 - 13 through	4.00 (101.60)	.19 (4.76)	.25 (6.35)	.56 (14.23)			\$1,300	B2	
81,000	125 - 130	5-55-2045-00	1.06 (26.99)	11.00 (279.40)	14.00 (355.60)	16.002 (406.451)	12.499 (317.475)	16.50 (419.10)	.62 (15.88)	5/8 - 11 through	9.75 (247.65)	.19 (4.76)	.25 (6.35)	.87 (22.10)			\$1,875	C1	
81,000	125 - 230	5-55-2041-00			7.25 (184.15)	8.500 (215.900)	12.499 (317.475)	12.499 (317.398)	.50 (12.70)		6.00 (152.40)			.93 (23.62)			\$1,325	C1	
81,000		5-55-2043-00	1.12 (28.58)	11.00 (279.40)		10.500 (266.700)	12.496 (317.398)	12.496 (317.398)	.50 (12.70)	5/8 - 11 through	7.75 (196.85)	.19 (4.76)	---	.93 (23.62)			\$1,325	C1	
82,000 and 82,300*	125 - 550	5-55-2046-00	1.94 (49.21)		14.00 (355.60)	16.002 (406.451)	12.499 (317.398)	16.50 (419.10)	.62 (15.88)	5/8 - 11 x 1 deep	9.50 (241.30)			1.75 (44.45)			\$1,875	C1	
82,000 and 82,300*		5-55-2042-00	1.38 (34.92)	11.00 (279.40)	7.25 (184.15)	8.500 (215.900)	12.496 (317.475)	13.25 (336.55)	.50 (12.70)	5/8 - 11 through	6.00 (152.40)	.19 (4.76)	.25 (6.35)	1.19 (30.23)			\$1,325	C1	
82,000 and 82,300*		5-55-2044	1.38 (34.92)		9.00 (228.60)	10.500 (266.700)	12.499 (317.398)	13.25 (336.55)	.50 (12.70)	5/8 - 11 through	7.75 (196.85)			1.19 (30.23)			\$2,075	C1	
86,000	500 - 1000	5-55-6041-00	1.56 (38.69)	14.00 (355.60)	11.00 (279.40)	12.500 (317.500)	16.000 (406.400)	16.19 (411.16)	.62 (15.88)	5/8 - 11 x 3/4 deep	8.62 (219.08)	.19 (4.76)	.25 (6.35)	1.37 (34.80)			\$2,800	C1	

* 1/2-13 flat head screws are supplied with adapter.

** When adding an adapter to a hazardous location brake, refer to the "mounting requirements" on the product page for the recommended brake series for accommodating adapters.

Foot Mounting Kits

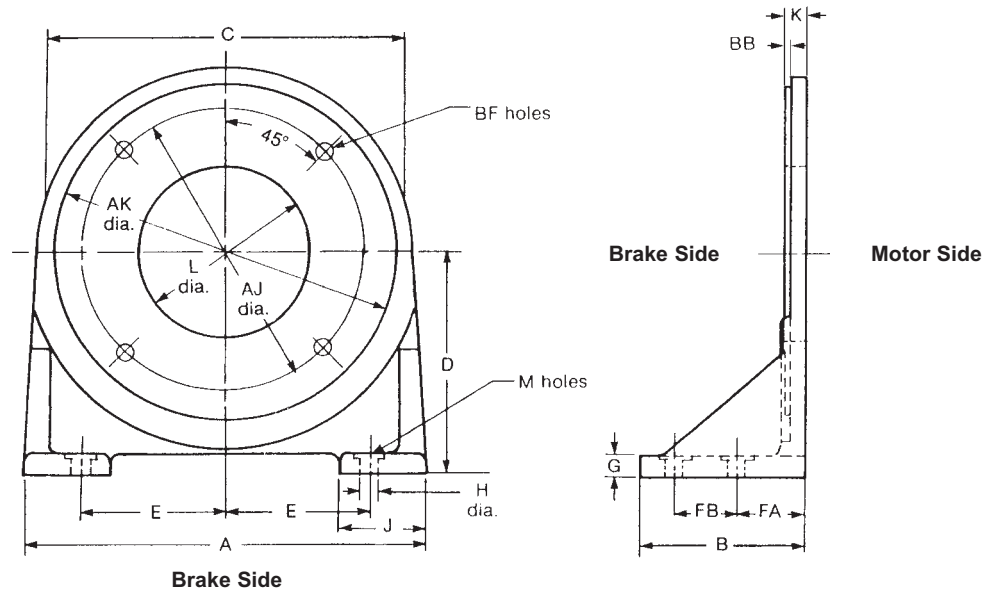

Kits include the foot mounting bracket and hardware to fit the BF mounting holes.

Dimensions for estimating only. For installation purposes, request certified prints.

Brake Series	Torque	Foot Mounting Kit Number	Dimensions in Inches (Dimensions in Millimeters)																Wgt. lbs.	List Price	Discount Symbol		
			A	AJ	AK	B	BB	BF		C	D	E	FA	FB	G	H	J	K				L	M
								No.	Thd.														
56,000	1.5-25	5-55-5023-00	7.00 (177.80)	5.88 (149.22)	$\frac{4.499}{4.498}$ (114.275) (114.249)	2.38 (60.32)	.12 (3.18)	2	3/8-16	6.50 (165.10)	3.50 (88.90)	2.88 (73.02)	1.50 (38.10)	-	.38 (9.52)	.41 (10.32)	1.50 (38.10)	.50 (12.70)	2.50 (63.50)	2	4.5	\$500.00	B4
87,000	6-105	5-55-7021-00	8.62 (219.08)	7.25 (184.15)	$\frac{8.499}{8.498}$ (215.875) (215.849)	3.00 (76.20)	.25 (6.35)	4	1/2-13	8.62 (218.95)	5.00 (127.00)	3.56 (90.49)	2.00 (50.80)	-	.38 (9.52)	.53 (13.49)	1.62 (41.28)	.56 (14.29)	5.75 (146.05)	2	7	575.00	B2
81,000	125-230	5-55-2022-00	15.50 (393.70)	11.00 (279.40)	$\frac{12.499}{12.498}$ (317.475) (317.449)	7.00 (177.80)	.25 (6.35)	4	5/8-11	13.25 (336.55)	8.50 (215.90)	6.88 (174.62)	2.00 (50.80)	4.00 (101.60)	.62 (15.88)	.69 (17.46)	3.00 (76.20)	.88 (22.22)	9.00 (228.60)	4	40	1,325.00	C1
82,000	125-550		18.25 (463.55)	14.00 (355.60)	$\frac{16.000}{15.995}$ (406.400) (406.273)	8.00 (203.20)	.22 (5.56)	4	5/8-11	17.00 (431.80)	10.88 (276.22)	6.38 (161.92)	3.38 (85.72)	3.00 (76.20)	1.00 (25.40)	.81 (20.64)	4.12 (104.78)	1.22 (30.96)	8.50 (215.90)	4	75	3,900.00	C1

Dimensions for C-Face Brake Motor Systems

Brakes Externally Wired to Motor

C-face motor with double shaft extension.

Stearns Disc Brakes are designed to mount on standard C-face motors having the same dimensions and tolerances on the accessory end as on the drive end. They also mount on foot mounting brackets and machine mounting faces having the same mounting dimensions and tolerances. Some motor accessory end C-face may differ from the drive end.

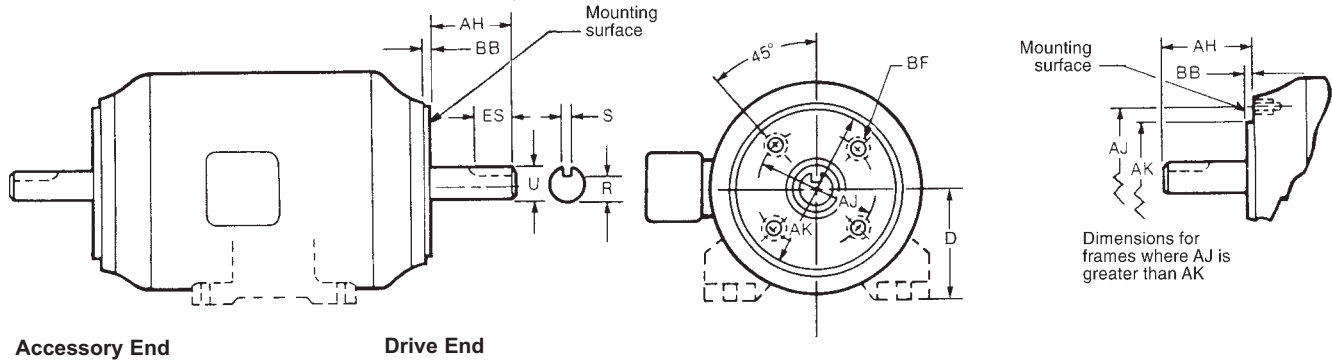

Drive End Dimensions (Inches)

Frame Designation	AJ	AK	BB Min.	BF Hole			U	AH	Keyseat			Base to Centerline D
				Number	Tap Size	Bolt Penetration Allowance			R	ES Min.	S	
42C	3.750	3.000	0.16	4	1/4-20	...	0.375	1.312	0.328	...	flat	2.62
48C	3.750	3.000	0.16	4	1/4-20	...	0.500	1.69	0.453	...	flat	3.00
56C	5.875	4.500	0.16	4	3/8-16	...	0.625	2.06	0.517	1.41	0.188	3.50
143TC and 145TC	5.875	4.500	0.16	4	3/8-16	0.56	0.875	2.12	0.771	1.41	0.188	3.50
182TC and 184TC	7.250	8.500	0.25	4	1/2-13	0.75	1.125	2.62	0.986	1.78	0.250	4.50
182TCH and 184TCH	5.875	4.500	0.16	4	3/8-16	0.56	1.125	2.62	0.986	1.78	0.250	4.50
213TC and 215TC	7.250	8.500	0.25	4	1/2-13	0.75	1.375	3.12	1.201	2.41	0.312	5.25
254TC and 256TC	7.250	8.500	0.25	4	1/2-13	0.75	1.625	3.75	1.416	2.91	0.375	6.25
284TC and 286TC	9.000	10.500	0.25	4	1/2-13	0.75	1.875	4.38	1.591	3.28	0.500	7.00
284TSC and 286TSC	9.000	10.500	0.25	4	1/2-13	0.75	1.625	3.00	1.416	1.91	0.375	7.00
324TC and 326TC	11.000	12.500	0.25	4	5/8-11	0.94	2.125	5.00	1.845	3.91	0.500	8.00
324TSC and 326TSC	11.000	12.500	0.25	4	5/8-11	0.94	1.875	3.50	1.591	2.03	0.500	8.00
364TC and 365TC	11.000	12.500	0.25	8	5/8-11	0.94	2.375	5.62	2.021	4.28	0.625	9.00
364TSC and 365TSC	11.000	12.500	0.25	8	5/8-11	0.94	1.875	3.50	1.591	2.03	0.500	9.00
404TC and 405TC	11.000	12.500	0.25	8	5/8-11	0.94	2.875	7.00	2.450	5.65	0.750	10.00
404TSC and 405TSC	11.000	12.500	0.25	8	5/8-11	0.94	2.125	4.00	1.845	2.78	0.500	10.00
444TC and 445TC	14.000	16.000	0.25	8	5/8-11	0.94	3.375	8.25	2.880	6.91	0.875	11.00
444TSC and 445TSC	14.000	16.000	0.25	8	5/8-11	0.94	2.375	4.50	2.021	3.03	0.625	11.00
500 Frame Series	14.500	16.500	0.25	4	5/8-11	0.94	12.50

Tolerances (Inches)

AK Dimension, Face Runout, Permissible Eccentricity of Mounting Rabbet

AK Dimension	Tolerance on AK Dimension		Maximum Face Runout	Maximum Permissible Eccentricity of Mounting Rabbet
	Plus	Minus		
Less than 12	0.000	0.003	0.004	0.004
12 and Larger	0.000	0.005	0.007	0.007

Shaft Extension Diameters

Shaft Diameter	Tolerances	
	Plus	Minus
0.2500 to 1.5000, inclusive	0.000	0.0005
Over 1.5000 to 6.500, inclusive	0.000	0.001

Width of Shaft Extension Keyseats

Width of Keyseat	Tolerances	
	Plus	Minus
0.188 to 0.750, inclusive	0.002	0.000
Over 0.750 to 1.500, inclusive	0.003	0.000

Shaft Runout

Shaft Diameter	Maximum Permissible Shaft Runout
0.3750 to 1.625, inclusive	0.002
Over 1.625 to 6.500, inclusive	0.003

SOURCE: ANSI/NEMA Standards Publication No. MG 1-1987; Part 4 and Part 11.

Dimensions for C-Face AC Brake Motor System (cont.)

Accessory End

FC face mounting for accessories, including brakes, on the end opposite the drive end of motor. Some motor accessory end C-face may differ from the drive end. Confirm shaft diameter and bolt circle before ordering.

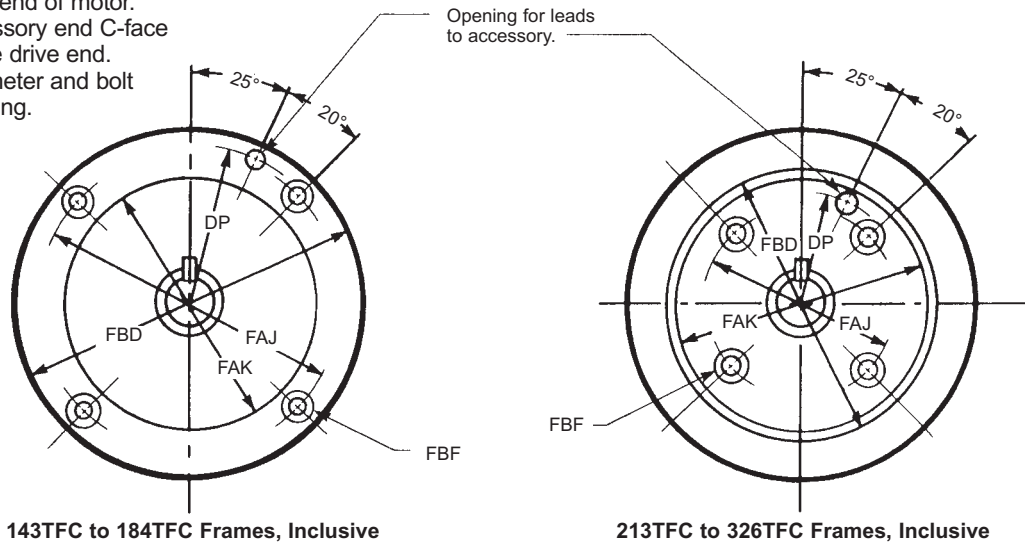

143TFC to 184TFC Frames, Inclusive

213TFC to 326TFC Frames, Inclusive

Dimensions (Inches)

Frame Designation	FAJ	FAK	FBD Max.	FBF Hole			Hole for Accessory Leads	
				Number	Tap Size	Bolt Penetration Allowance	DP	Diameter
143TFC and 145TFC	5.875	4.500	6.50	4	3/8-16	0.56	2.81	0.41
182TFC and 184TFC	5.875	4.500	6.50	4	3/8-16	0.56	2.81	0.41
213TFC and 215TFC	7.250	8.500	9.00	4	1/2-13	0.75	3.81	0.62
254TFC and 256TFC	7.250	8.500	10.00	4	1/2-13	0.75	3.81	0.62
284TFC and 286TFC	9.000	10.500	11.25	4	1/2-13	0.75	4.50	0.62
324TFC and 326TFC	11.000	12.500	14.00	4	5/8-11	0.94	5.25	0.62

NOTE: Standards have not been developed for the shaft extension diameter and length, and keyseat dimensions.

Tolerances* (Inches)

FAK Dimension, Face Runout, Permissible Eccentricity of Mounting Rabbet

FAK Dimension	Tolerance on FAK Dimension		Maximum Face Runout	Maximum Permissible Eccentricity of Mounting Rabbet
	Plus	Minus		
Less than 12	0.000	0.003	0.004	0.004
12 and Larger	0.000	0.005	0.007	0.007

* Tolerance requirement on 56,X00 and 87,000 Series Brake kits is .015 T.I.R. (total indicated runout shaft to motor register face).

Shaft Runout

Shaft Diameter	Maximum Permissible Shaft Runout
0.3750 to 1.625, inclusive	0.002
Over 1.625 to 6.500, inclusive	0.003

SOURCE: ANSI/NEMA Standards Publication No. MG 1-1987; Part 4 and Part 11.

Stearns Recommended Minimum Shaft Diameter by Torque

Minimum recommended shaft size considers a keyed C1045 steel shaft under dynamic use in a typical spring set brake application.

Torque ft-lb	Minimum Shaft (inches)
0.50	0.250
0.75	0.250
1.5	0.375
3	0.500
6	0.500
10	0.625
15	0.750
25	0.875
35	1.000
50	1.125

Torque ft-lb	Minimum Shaft (inches)
75	1.250
105	1.375
125	1.375
175	1.625
230	1.750
330	2.000
440	2.125
500	2.375
750	2.500
1000	2.750

Torque Nm	Minimum Shaft (mm)
4 Nm	ø10 mm
8 Nm	ø13 mm
16 Nm	ø16 mm
32 Nm	ø20 mm
60 Nm	ø25 mm
80 Nm	ø28 mm
150 Nm	ø34 mm
240 Nm	ø39 mm
400 Nm	ø47 mm

Set and Release Times

The models listed below were tested for typical set and release times. Times listed below are defined as follows:

T1 = Total set time to 80% of rated static torque T2 = Release time, measured as the time from when the power is applied to the brake to the time that the solenoid plunger or armature is fully seated.

NOTE: Times will vary with the motor used, and brakes tested with factory-set air gap. The times shown should be used as a guide only.

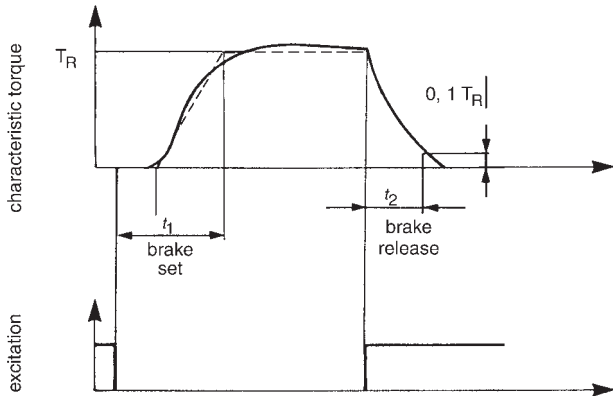

SAB T1/T2 Time in Milliseconds

Series	Static Torque lb-ft	Coil Size	T1 AC	T2 AC
56,000	1 1/2 - 25	K4, K4, K4+, M4+	25	14
87,000	10,15, 25,50	5 & 6	42	20
87,000	35,75,105	8	48	20
81,000 82,000	All	9	56	27

Brake and motor are switched separately.
All brakes tested in horizontal position.
Coil is energized for >24 hours before testing.
Ambient temperature 70°F at time of test.

AAB Series 310/311/320/321 Times in Milliseconds

Series	310 DC Side Switching					
Size	1.79	2.0	2.87	3.35	4.25	5.0
T1	3	6	9	14	13	22
T2	20	43	48	110	120	195
Series	311 DC Side Switching					
Size	3.38	4.75	5.0			
T1	43	48	96			
T2	12	74	35			
Series	320 DC Side Switching					
Size	1.2	1.8	2.0	2.8		
T1	14	43	16	27		
T2	24	26	35	34		
Series	320 Full wave rectifier/AC Side Switching					
Size	1.2	1.8	2.0	2.8		
T1	31	97	52	78		
T2	27	29	40	42		
Series	321 DC Side Switching			321 AC Side Switching		
Size	1.2	1.8	2.8	1.2	1.8	2.8
T1	13	16	20	45	77	131
T2	18	27	49	16	25	26

AAB Series 333 Times in Milliseconds

Size	Applied Voltage/Type of Switching	T1	T2
72	DC side switching	23	35
	230 Vac/ac side switching/full wave	103	39
	460 Vac/ac side switching/half wave	98	34
90	DC side switching	19	73
	230 Vac/ac side switching/full wave	113	72
	460 Vac/ac side switching/half wave	114	73
	230 Vac connected across motor full wave	357	72
112	230 Vac connected across motor /quickset	42	72
	DC side switching	155	39
	230 Vac/ac side switching/full wave	547	43
132	460 Vac/ac side switching/half wave	501	54
	DC side switching	119	100
	230 Vac/ac side switching/full wave	833	101
145	460 Vac/ac side switching/half wave	803	106
	DC side switching	185	186
	230 Vac/ac side switching/full wave	999	192
	460 Vac/ac side switching/half wave	1007	209
	230 Vac connected across motor full wave	1689	192
	230 Vac connected across motor /quickset	368	192
170	460 Vac/ac side switching/half wave/With air gap shim	629	223
	DC side switching	129	163
	230 Vac/ac side switching/full wave	1130	174
196	460 Vac/ac side switching/half wave	1140	175
	DC side switching	96	263
	230 Vac/ac side switching/full wave	920	264
230	460 Vac/ac side switching/half wave	957	274
	DC side switching	131	264
	230 Vac/ac side switching/full wave	1299	236
	460 Vac/ac side switching/half wave	1303	276
	Tor-Ac 230 Vac/ac side switching/full wave	169	295
	Tor-Ac 230 Vac/ac side switching/full wave/With air gap shim	122	327
278	230 Vac connected across motor quickset/quickrelease/with air gap shim	122	145
	DC side switching	182	388
	230 Vac/ac side switching/full wave	1807	389
	460 Vac/ac side switching/half wave	1689	366

Conversions

English-Metric Conversion Factors

Multiply the base unit by the factor shown to obtain the desired conversion.

Measurement	Base Unit	Factor	Conversion
Length	inch, in (<i>millimeter, mm</i>)	25.4 .03937	(<i>millimeter, mm</i>) inch, in
Torque	pound-feet, lb-ft (<i>newton-meter, Nm</i>) pound-inch, lb-in (<i>newton-meter, Nm</i>) ounce-inch, oz-in (<i>newton-meter, Nm</i>)	1.355818 .73756 .113 8.85 .007062 141.611	(<i>newton-meter, Nm</i>) pound-feet, lb-ft (<i>newton-meter, Nm</i>) pound-inch, lb-in (<i>newton-meter, Nm</i>) ounce-inch, oz-in
Moment of Inertia	pound-feet squared, lb-ft ² (<i>kilogram-meter squared, kgm²</i>)	.042 23.81	(<i>kilogram-meter squared, kgm²</i>) pound-feet squared, lb-ft ²
Kinetic Energy	foot-pound, ft-lb (<i>joule, J</i>)	1.355818 .73756	(<i>joule, J</i>) foot-pound, ft-lb
Weight	pound, lb (<i>kilogram, kg</i>)	.453592 2.20462	(<i>kilogram, kg</i>) pound, lb
Horsepower (English)	horsepower, hp (<i>kilowatt, kW</i>)	.7457 1.341	(<i>kilowatt, Kw</i>) horsepower, hp
Thermal Capacity	horsepower-seconds per minute, hp-sec/min (<i>watts, W</i>)	12.42854 .08046	(<i>watts W</i>) horsepower-seconds per minute, hp-sec/min
Temperature	degrees Fahrenheit, °F (<i>degrees Celsius, °C</i>)	(°F - 32) x 5/9 (°C x 9/5) + 32	(<i>degrees Celsius, °C</i>) degrees Fahrenheit, °F

English-English Conversion Factors for Thermal Capacity

Base Unit	Multiply by	To Obtain
horsepower	60.0	hp-sec/min
ft-lb/sec	.109	hp-sec/min
ft-lb/min	.0018	hp-sec/min
in-lb/sec	.009	hp-sec/min
in-lb/min	.00015	hp-sec/min

Decimal Equivalents of Fractions

Decimal Equivalent (Inches)		Fraction (Inches)
2-Place	3-Place	
.02	.016	1/64
.03	.031	1/32
.05	.047	3/64
.06	.062	1/16
.08	.078	5/64
.09	.094	3/32
.11	.109	7/64
.12	.125	1/8
.14	.141	9/64
.16	.156	5/32
.17	.172	11/64
.19	.188	3/16
.20	.203	13/64
.22	.219	7/32
.23	.234	15/64
.25	.250	1/4
.27	.266	17/64
.28	.281	9/32
.30	.297	19/64
.31	.312	5/16
.33	.328	21/64
.34	.344	11/32
.36	.359	23/64
.38	.375	3/8

Decimal Equivalent (Inches)		Fraction (Inches)
2-Place	3-Place	
.39	.391	25/64
.41	.406	13/32
.42	.422	27/64
.44	.438	7/16
.45	.453	29/64
.47	.469	15/32
.48	.484	31/64
.50	.500	1/2
.52	.516	33/64
.53	.531	17/32
.55	.547	35/64
.56	.562	9/16
.58	.578	37/64
.59	.594	19/32
.61	.609	39/64
.62	.625	5/8
.64	.641	41/64
.66	.656	21/32
.67	.672	43/64
.69	.688	11/16
.70	.703	45/64
.72	.719	23/32
.73	.734	47/64
.75	.750	3/4

Decimal Equivalent (Inches)		Fraction (Inches)
2-Place	3-Place	
.77	.766	49/64
.78	.781	25/32
.80	.797	51/64
.81	.812	13/16
.83	.828	53/64
.84	.844	27/32
.86	.859	55/64
.88	.875	7/8
.89	.891	57/64
.91	.906	29/32
.92	.922	59/64
.94	.938	15/16
.95	.958	61/64
.97	.969	31/32
.98	.984	63/64
1.00	1.000	1

Application Engineering

Introduction

Information and guidelines provided in the application section are intended for general selection and application of spring set brakes. Unusual operating environments, loading or other undefined factors may affect the proper application of the product. Stearns application services are available to assist in proper selection or to review applications where the specifier may have questions.

A spring set brake is used to stop and hold a rotating shaft. Generally the brake is mounted to an electric motor, but can also be mounted to gear reducers, hoists, machinery or utilize a foot mount kit.

The brake should be located on the high speed shaft of a power transmission system. This permits a brake with the lowest possible torque to be selected for the system.

Spring set disc brakes use friction to stop (dynamic torque) and hold (static torque) a load. Energy of the motor rotor and moving load is converted to thermal energy (heat) in the brake during deceleration. The brakes are power released, spring applied. No electrical current is required to maintain the spring set condition.

The system designer will need to consider the mount surface and match the brake to the load and application. Factors include: brake torque, stopping time, deceleration rate, load weight and speed, location and environment. Brake thermal ratings, electrical requirements and environmental factors are discussed in separate sections.

Electrical Considerations

Solenoid actuated brakes (SAB's) are available with standard motor voltages, frequencies and Class B or H coil insulation. Most models can be furnished with either single or dual voltage coils. Coils in most models are field replaceable.

Inrush and holding amperage information is published for the common coil voltages and factory available for other voltages or frequencies. Amperage information for specific coil sizes is provided for selection of wire size and circuit protection at brake installation. Fixed voltage - 50/60 Hz dual frequency coils are available in many models.

All SAB AC coils are single phase and can be wired to either single or three phase motors without modifications. All solenoid coils have a voltage range of +/- 10% of the rated nameplate voltage at the rated frequency. Instantaneous rated voltage must be supplied to the coil to insure proper solenoid pull in and maximum coil cycle rate. The plunger rapidly seats in the solenoid and the

amperage requirements drops to a holding amperage value.

Instantaneous voltage must be supplied to the coil to insure proper solenoid pull-in and maximum coil cycle rate.

Because Stearns Solenoid Actuated Brakes (SAB's) require low current to maintain the brake in the released position, the response time to set the brake *can* be affected by EMF voltages generated by the motor windings. It may be necessary to isolate the brake coil from the motor winding.

The solenoid coil cycle rate limits the engagements per minute of a static or holding duty brake. Brake thermal performance, discussed in another section, limits engagements per minute in dynamic applications.

Class B insulation is standard in most SAB models, class H coil insulation is optional and is recommended for environments above 104°F (40°C), or rapid cycling applications.

Armature actuated brakes (AAB's) are available in standard DC voltages. Available AC rectification is listed in the catalog section. Wattage information is provided in the catalog pages. Unlike solenoid actuated brakes, armature actuated brakes do not have inrush amperage. Coil and armature reaction time and resulting torque response time information is available. Like SAB, mechanical reaction time depends on typical application factors including load, speed and position.

Electrical response time and profiles are unique to the SAB and AAB. Reaction time requirements should be considered when selecting or interchanging brakes.

All Stearns brake coils are rated for continuous duty and can be energized continually without overheating. The coil heating effect is greatest at coil engagement due to engaging, pull in or inrush amperage.

Temperature limits as established by UL controls standards are:

Class A insulation	221°F (105°C)
Class B insulation	266°F (130°C)
Class H insulation	356°F (180°C).

Types of Applications

In order to simplify the selection of a disc brake, loads can be classified into two categories, non-overhauling and overhauling.

Loads are classified as non overhauling, if (1) no components of the connected equipment or external material undergo a change of height, such as would occur in hoisting, elevating or lowering a load, and (2) there is only rotary motion in a horizontal plane. For example, a loaded conveyor operating in a horizontal plane

would be typical of a non-overhauling load.

If the same conveyor were transporting material to a lower level, it would be classified as an overhauling load. The external material or load undergoes a change in height, with the weight of the load attempting to force the conveyor to run faster than its design speed or to overhaul.

Non-overhauling loads require braking torque only to stop the load and will remain at rest due to system friction. Overhauling loads, such as a crane hoist, have two torque requirements. The first requirement is the braking torque required to *stop* the load, and the second requirement is the torque required to *hold* the load at rest. The sum of these requirements is considered when selecting a brake for an overhauling load.

Alignment

Requirements per NEMA:

Permissible ECCENTRICITY of mounting rabbet (AK dimension):

42C to 286TC frames inclusive is 0.004" total indicator reading. 324TC to 505TC frames inclusive is 0.007" total indicator reading.

Face Runout:

42C to 286TC frames inclusive is 0.004" total indicator reading.

If a customer furnishes a face on the machine for brake mounting, the same tolerances apply. Floor mounted brakes must be carefully aligned within 0.005" for concentricity and angular alignment. Use of dowels to insure permanent alignment is recommended.

In offset brake mount locations such as fan covers, cowls or jack shafting, proper mount rigidity and bearing support must be provided. Spring set frictional brakes characteristically have a rapid stop during torque application which may affect the mount surface or contribute to shaft deflection.

Printed installation information is published and available on all Stearns spring set brakes.

Determining Brake Torque

Torque ratings

Brake torque ratings are normally expressed as nominal static torque. That is, the torque required to begin rotation of the brake from a static, engaged condition. This value is to be distinguished from dynamic torque, which is the retarding torque required to stop a linear, rotating or overhauling load.

As a general rule, a brake's dynamic torque is approximately 80% of the static torque rating of the brake for stopping time up to one second. Longer stopping time will produce additional brake heat and possible fading (reduction) of dynamic torque. The required dynamic torque must be converted to a static torque value before selecting a brake, using the relationship:

$$T_s = \frac{T_d}{0.8}$$

Where, T_s = Static torque, lb-ft

T_d = Dynamic torque, lb-ft

0.8 = Constant
(derating factor)

All Stearns brakes are factory burnished and adjusted to produce no less than rated nominal static torque. Burnishing is the initial wear-in and mating of the rotating friction discs with the stationary metallic friction surfaces of the brake.

Although brakes are factory burnished and adjusted, variations in torque may occur if components are mixed when disassembling and reassembling the brake during installation. Further burnishing may be necessary after installation. Friction material will burnish under normal load conditions. Brakes used as holding only duty require friction material burnishing at or before installation to insure adequate torque.

When friction discs are replaced, the brake must be burnished again in order to produce its rated holding torque.

System Friction

The friction and rolling resistance in a power transmission system is usually neglected when selecting a brake. With the use of anti-friction bearings in the system, friction and rolling resistance is usually low enough to neglect. Friction within the system will assist the brake in stopping the load. If it is desired to consider it, subtract the frictional torque from the braking torque necessary to decelerate and stop the load. Friction and rolling resistance are neglected in the examples presented in this guide.

Non-overhauling Loads

There are two methods for determining brake torque for non-overhauling loads. The first method is to size the brake to the torque of the motor. The second is to select a brake on the basis of the total system or load inertia to be stopped.

Selecting Brake Torque from the Motor Data

Motor full-load torque based or nameplate horsepower and speed can be used to select a brake. This is the most common method of selecting a brake torque rating due to its simplicity.

This method is normally used for simple rotary and linear inertial loads. Brake torque is usually expressed as a percent of the full load torque of the motor. Generally this figure is not less than 100% of the motor's full load torque. Often a larger service factor is considered. Refer to *Selection of Service Factor*.

The required brake torque may be calculated from the formula:

$$T_s = \frac{5,252 \times P}{N} \times SF$$

Where, T_s = Static brake torque, lb-ft

P = Motor horsepower, hp

N = Motor full load speed, rpm

SF = Service factor

5,252 = Constant

Match the brake torque to the hp used in the application. When an oversized motor hp has been selected, brake torque based on the motor hp may be excessive for the actual end use.

Nameplate torque represents a nominal static torque. Torque will vary based on combinations of factors including cycle rate, environment, wear, disc burnish and flatness. Spring set brakes provide a rapid stop and hold and are generally not used in repeat positioning applications.

Selection of Service Factor

A service factor is applied to the basic drive torque calculation. The SF compensates for any tolerance variation, data inaccuracy, unplanned transient torque and potential variations of the friction disc.

When using the basic equation:

$T = (\text{hp} \times 5252) / \text{rpm}$ with non-overhauling loads, a service factor of 1.2 to 1.4 is typical. Overhauling loads with unknown factors such as reductions may use a service factor of 1.4 to 1.8.

Spring set brakes combined with variable frequency drives use service factors ranging from 1.0 to 2.0 (2.0 for holding duty only) depending on the system design. These holding duty brakes must be wired to a separate dedicated power supply.

Occasionally, a brake with a torque rating less than the motor full load torque or with a service factor less than 1.0 is selected. These holding or soft stop applications must be evaluated by the end user or system designer to insure adequate sizing and thermal capacity.

Typically a brake rated 125% of the motor full load torque, or with a 1.25 service factor, provides a stop in approximately the same time as that required for the motor to accelerate the load to full load speed.

Occasionally a motor is oversized or undersized for the load or application. In these situations, the load inertia and desired stopping time calculations should be used rather than relying on the service factor method alone.

Service factor selection can be based on motor performance curves. Motor rotor and load inertia should be considered in this selection process. Depending on the motor design (NEMA A, B, C and D), rpm and horsepower, the maximum torque is either the starting or breakdown torque. A NEMA design B, 3 phase, squirrel cage design motor at breakdown torque produces a minimum of 250% the full load torque. A service factor of 2.5 would be selected. Typical service factors depending on NEMA motor design are: NEMA design A or B: 1.75 to 3.0, NEMA design C: 1.75 to 3.0 and NEMA design D: not less than 2.75.

A brake with an excessive service factor may result in system component damage, an unreasonably rapid stop or loss of load control. A SF above 2.0 is not recommended without evaluation by the end user or system designer.

Example 1: Select brake torque from motor horsepower and speed.

Given: Motor power (P) - 5 hp

Motor speed (N) - 1,750 rpm

Service factor (SF) - 1.4

$$T = \frac{5,252 \times P}{N} \times SF$$

$$= \frac{5,252 \times 5}{1,750} \times 1.4$$

$$T = 21 \text{ lb-ft}$$

A brake having a standard rating of 25 lb-ft nominal static torque would be selected.

Example 2 illustrates selection of a brake to provide proper static torque to hold a load if dynamic braking were used to stop the load.

Example 2: Select a brake to hold a load in position after some other method, such as dynamic braking of the motor, has stopped all rotation.

Given: Weight of load (W) - 5 lb

Drum radius (R) - 2 ft

Service factor (SF) - 1.4

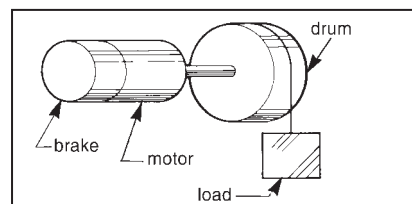

The static holding torque is determined by the weight of the load applied at the drum radius. A service factor is applied to ensure sufficient holding torque is available in the brake.

$$T_s = F \times R \times SF$$

$$= 5 \times 2 \times 1.4$$

$$T_s = 14 \text{ lb-ft}$$

Sizing the Brake to the Inertial Load

For applications where the load data is known, where high inertial loads exist, or where a stop in a specified time or distance is required, the brake should be selected on the basis of the total inertia to be retarded. The total system inertia, reflected to the brake shaft speed, would be:

$$Wk_T^2 = Wk_B^2 + Wk_M^2 + Wk_L^2$$

Where: Wk_T^2 = Total inertia reflected to the brake, lb-ft²

Wk_B^2 = Inertia of brake, lb-ft²

Wk_M^2 = Inertia of motor rotor, lb-ft²

Wk_L^2 = Equivalent inertia of load reflected to brake shaft, lb-ft²

Other significant system inertias, including speed reducers, shafting, pulleys and drums, should also be considered in determining the total inertia the brake would stop.

If any component in the system has a rotational speed different than the rotational speed of the brake, or any linear moving loads are present, such as a conveyor load, their equivalent inertia in terms of rotary inertia at the brake rotational speed must be determined. The following formulas are applicable:

Rotary motion:

$$\text{Equivalent } Wk_B^2 = Wk_L^2 \left(\frac{N_L}{N_B} \right)^2$$

Where,

Equivalent Wk_B^2 = Inertia of rotating load reflected to brake shaft, lb-ft²

Wk_L^2 = Inertia of rotating load, lb-ft²

N_L = Shaft speed at load, rpm

N_B = Shaft speed at brake, rpm

Horizontal Linear Motion

$$\text{Equivalent } Wk_W^2 = W \left(\frac{V}{2\pi N_B} \right)^2$$

Where,

Equivalent Wk_W^2 = Equivalent inertia of linear moving load reflected to brake shaft, lb-ft²

W = Weight of linear moving load, lb

V = Linear velocity of load, ft/min

N_B = Shaft speed at brake, rpm

Once the total system inertia is calculated, the required average dynamic braking torque can be calculated using the formula:

$$T_d = \frac{Wk_T^2 \times N_B}{308 \times t}$$

Where, T_d = Average dynamic braking torque, lb-ft

Wk_T^2 = Total inertia reflected to brake, lb-ft²

N_B = Shaft speed at brake, rpm

t = Desired stopping time, sec

308 = Constant

The calculated dynamic torque is converted to the static torque rating using the relationship:

$$T_s = \frac{T_d}{0.8}$$

Where, T_s = Brake static torque, lb-ft

T_d = System dynamic torque, lb-ft

Examples 3, 4, 5 and 6 illustrate how brake torque is determined for non-overhauling loads where rotary or horizontal linear motion is to be stopped.

Example 3: Select a brake to stop a rotating flywheel in a specified time.

Given, Motor speed (N_M) - 1,750 rpm

Motor inertia (Wk_M^2) - 0.075 lb-ft²

Flywheel inertia (Wk_{FW}^2) - 4 lb-ft²

Brake inertia (Wk_B^2) - 0.042 lb-ft²

Required stopping time (t) - 1 sec

First determine the total inertia to be stopped,

$$Wk_T^2 = Wk_M^2 + Wk_{FW}^2 + Wk_B^2$$

$$= 0.075 + 4 + 0.042$$

$$Wk_T^2 = 4.117 \text{ lb-ft}^2$$

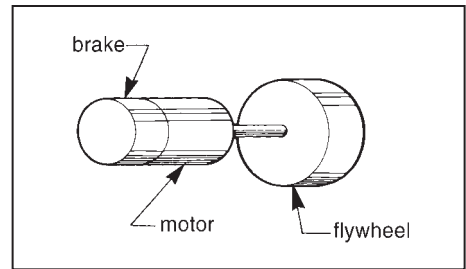

The dynamic braking torque required to stop the total inertia in 1 second is,

$$T_d = \frac{Wk_T^2 \times N_{BM}}{308 \times t}$$

$$= \frac{4.117 \times 1,750}{308 \times 1}$$

$$T_d = 23.4 \text{ lb-ft}$$

Converting T_d to static torque

$$T_s = \frac{T_d}{0.8}$$

$$= \frac{23.4}{0.8}$$

$$T_s = 29.3 \text{ lb-ft}$$

A brake having a standard static torque rating of 35 lb-ft would be selected. Since a brake with more torque than necessary to stop the flywheel in 1 second is selected, the stopping time would be,

$$t = \frac{Wk_T^2 \times N_{BM}}{308 \times T_d}$$

$$= \frac{Wk_T^2 \times N_{BM}}{308 \times (0.8 T_s)}$$

$$\frac{4.117 \times 1,750}{308 \times (0.8 \times 35)}$$

$$t = 0.84 \text{ sec}$$

See section on *Stopping Time and Thermal Information*.

Example 4: Select a brake to stop a rotating flywheel, driven through a gear reducer, in a specified time.

Given: Motor speed (N_M) - 1,800 rpm

Motor inertia (Wk_M^2) - 0.075 lb-ft²

Gear reduction (GR) - 20:1

Gear reducer inertia at high speed shaft (Wk_{GR}^2) - 0.025 lb-ft²

Flywheel inertia (Wk_{FW}^2) - 20 lb-ft²

Required stopping time (t) -

0.25 sec

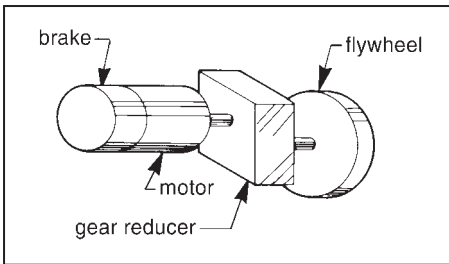

First, determine rotating speed of flywheel (N_{FW})

$$N_{FW} = \frac{N_{BM}}{GR}$$

$$= \frac{1,800}{20}$$

$$N_{FW} = 90 \text{ rpm}$$

Next, the inertia of the flywheel must be reflected back to the motor brake shaft.

$$Wk_b^2 = Wk_{FW}^2 \left(\frac{N_{FW}}{N_M} \right)^2$$

$$= 20 \left(\frac{90}{1,800} \right)^2$$

$$Wk_b^2 = 0.05 \text{ lb-ft}^2$$

Determining the total Wk^2 ,

$$Wk_i^2 = Wk_M^2 + Wk_{GR}^2 + Wk_b^2$$

$$= 0.075 + 0.025 + 0.05$$

$$Wk_i^2 = 0.15 \text{ lb-ft}^2$$

The required dynamic torque to stop the flywheel in 0.25 seconds can now be determined.

$$T_d = \frac{Wk_i^2 \times N_{BM}}{308 \times t}$$

$$T_d = \frac{0.15 \times 1,800}{308 \times 0.25}$$

$$T_d = 3.5 \text{ lb-ft}$$

Converting dynamic torque to static torque,

$$T_s = \frac{T_d}{0.8}$$

$$= \frac{3.5}{0.8}$$

$$T_s = 4.4 \text{ lb-ft}$$

A brake having a standard static torque rating of 6 lb-ft would be selected. Since a brake with more torque than necessary to stop the flywheel in 0.25 seconds is selected, the stopping time would be,

$$t = \frac{Wk_i^2 \times N_M}{308 \times T_d}$$

$$= \frac{Wk_i^2 \times N_M}{308 \times (0.8 \times T_s)}$$

$$= \frac{0.15 \times 1,800}{308 \times (0.8 \times 6)}$$

$$t = 0.18 \text{ sec}$$

See section on *Stopping Time and Thermal Information*.

Example 5: Select a brake to stop a load on a horizontal belt conveyor in a specified time.

Given:

Conveyor pulley speed (N_p) - 32 rpm

Weight of load (W) - 30 lb

Conveyor pulley and belt inertia (Wk_p^2) - 4.0 lb-ft²

Conveyor pulley diameter (d_p) - 1 ft

Required stopping time (t) - 0.25 sec

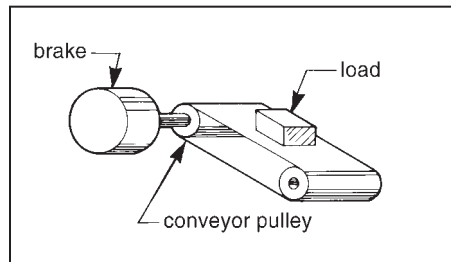

First, convert the rotational pulley speed to linear belt speed (V_B).

$$V_B = \pi d_p N_p$$

$$= \pi \times 1 \times 32$$

$$V_B = 100.5 \text{ ft/min}$$

Next, determine inertia of load.

$$Wk_W^2 = W \left(\frac{V_B}{2\pi \times N_p} \right)^2$$

$$= 30 \left(\frac{100.5}{2\pi \times 32} \right)^2$$

$$Wk_W^2 = 7.5 \text{ ft-lb}^2$$

Then, determine total inertial load

$$Wk_i^2 = Wk_W^2 + Wk_p^2$$

$$= 7.5 + 4.0$$

$$Wk_i^2 = 11.5 \text{ lb-ft}^2$$

The required dynamic torque to stop the conveyor load in 0.25 seconds can now be determined.

$$T_d = \frac{Wk_i^2 \times N_p}{308 \times t}$$

$$T_d = \frac{11.5 \times 32}{308 \times 0.25}$$

$$T_d = 4.8 \text{ lb-ft}$$

Converting dynamic torque to static torque,

$$T_s = \frac{T_d}{0.8}$$

$$= \frac{4.8}{0.8}$$

$$T_s = 6 \text{ lb-ft}$$

A brake having a standard static torque rating of 6 lb-ft would be selected. See *Thermal Information*.

Example 6: Select a brake to stop a trolley crane and its load in a specified time. Brake mounted on wheel axle.

Given:

Weight of crane (W_c) - 2,000 lb

Weight of load (W_l) - 100 lb

Trolley velocity (v) - 3 ft/sec or 180 ft/min

Radius of trolley wheel (r) - 0.75 ft

Required stopping time (t) - 2 sec

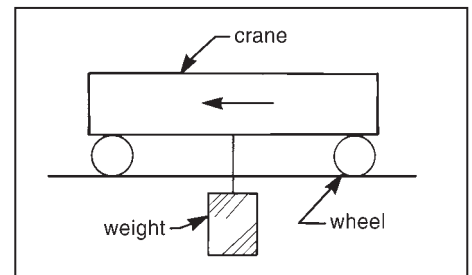

The dynamic braking torque required to stop the trolley crane and load can be determined by one of two methods. The first method is to determine the equivalent inertia of the linearly moving crane and load, then calculate the dynamic braking torque. The second method is to determine the dynamic braking torque directly.

Using the first method, the total weight to be stopped is determined first.

$$W_T = W_L + W_C$$

$$= 100 + 2,000$$

$$W_T = 2,100 \text{ lb}$$

Next, the rotational speed of the axle (N_B) is calculated.

$$N_B = \frac{V}{2\pi r}$$

$$= \frac{180}{2 \times \pi \times 0.75}$$

$$N_B = 38.2 \text{ rpm}$$

Then, the equivalent inertia of the linearly moving crane and load is determined.

$$Wk_f^2 = W_T \left(\frac{V}{2\pi N_B} \right)^2$$

$$= 2,100 \left(\frac{180}{2\pi \times 38.2} \right)^2$$

$$Wk_f^2 = 1,181 \text{ lb-ft}^2$$

Finally, the dynamic braking torque required to stop the total inertia in 2 seconds is,

$$T_d = \frac{Wk_f^2 \times N_B}{308 \times t}$$

$$= \frac{1,181 \times 38.2}{308 \times 2}$$

$$T_d = 73 \text{ lb-ft}$$

Using the second method, the dynamic braking torque required to stop the crane and load in 2 seconds can be calculated directly using the formula,

$$T_d = \frac{W_T v}{gt} \times r$$

Where, T_d = Average dynamic braking torque, lb-ft

W_T = Total weight of linear moving load, lb

v = Linear velocity of load, ft/sec

g = Gravitational acceleration constant, 32.2 ft/sec²

t = Desired stopping time, sec

r = Length of the moment arm (wheel radius), ft

or, for this example,

$$T_d = \frac{2,100 \times 3}{32.2 \times 2} \times .75$$

$$T_d = 73 \text{ lb-ft}$$

For both methods above, the required dynamic braking torque is converted to static torque,

$$T_s = \frac{T_d}{0.8}$$

$$= \frac{73}{0.8}$$

$$T_s = 91 \text{ lb-ft}$$

A smaller brake could be mounted on the high speed shaft in place of the higher torque on the low speed shaft.

A brake having a standard static torque rating of 105 lb-ft is selected. Since a brake with more torque than necessary to stop the load in 2 seconds is selected, the stopping time would be,

$$T = \frac{W_T v}{g T_d} \times r$$

$$= \frac{W_T v}{g \times (0.8 \times T_s)} \times r$$

$$= \frac{2,100 \times 3}{32.2 \times (0.8 \times 105)} \times 0.75$$

$$t = 1.8 \text{ sec}$$

See section on *Stopping Time* and cycle rates, *Thermal Selection*. Stops should be under 2 seconds. Longer stops require application test.

Overhauling Loads

Applications with a descending load, such as power lowered crane, hoist or elevator loads, require a brake with sufficient torque to both *stop* the load, and *hold* it at rest. Overhauling loads having been brought to rest still invite motion of the load due to the effect of gravity. Therefore, brake torque must be larger than the overhauling torque in order to stop and hold the load. If brake torque is equal to or less than the overhauling torque, there is no net torque available for stopping a descending load.

First, the total system inertia reflected to the brake shaft speed must be calculated.

Second, the average dynamic torque required to decelerate the descending load in the required time is calculated with the formula:

$$T_d = \frac{Wk_f^2 \times N_B}{308 \times t}$$

Where, T_d = Average dynamic braking torque, lb-ft

Wk_f^2 = Total inertia reflected to brake, lb-ft²

N_B = Shaft speed at brake, rpm. Consider motor slip when descending.

t = Desired stopping time, sec

Third, the overhauling torque reflected to the brake shaft is determined by the formula:

$$T_o = W \times R \times \frac{N_L}{N_B}$$

Where, T_o = Overhauling dynamic torque of load reflected to brake shaft, lb-ft

W = Weight of overhauling load, lb

R = Radius of hoist or elevator drum, ft

N_L = Rotating speed of drum, rpm

N_B = Rotating speed at brake, rpm

Or alternately, the dynamic torque to overcome the overhauling load can be calculated with the formula:

$$T_o = \frac{0.158 \times W \times V}{N_B}$$

Where, T_o = Overhauling dynamic torque of load reflected to brake shaft, lb-ft

W = Weight of overhauling load, lb

V = Linear velocity of descending load, ft/min

N_B = Shaft speed at brake, rpm

0.158 = Constant

Next, the total dynamic torque required to stop and hold the overhauling load is the sum of the two calculated dynamic torques:

$$T_t = T_d + T_o$$

Finally, the dynamic torque must be converted to static brake torque to select a brake:

$$T_s = \frac{T_d}{0.8}$$

Where, T_s = Brake static torque, lb-ft

T_t = System dynamic torque, lb-ft

If the total inertia of the system and overhauling load cannot be accurately determined, a brake rated at 180% the motor full load torque should be selected. Refer to *Selection of Service Factor*. The motor starting torque may permit a heavier than rated load to be lifted; the brake must stop the load when descending.

Examples 7, 8 and 9 illustrate how brake torque would be determined for overhauling loads. In these examples brakes are selected using the system data rather than sizing them to the motor. Refer to the section on *Thermal Calculations* to determine cycle rate.

Consider motor slip in calculation. An 1800 rpm motor with 10% slip would operate at 1,620 rpm when the load is ascending and 1,980 rpm when descending. Motor rpm, armature inertia and load position will affect stop time. Brakes on overhauling loads should be wired through a dedicated relay.

Example 7: Select a brake to stop an overhauling load in a specified time.

- Given: Cable speed (V) - 667 ft/min
- Weight of load (W) - 100 lb
- Drum diameter (D) - 0.25 ft
- Drum inertia (WK_d^2) - 5 lb-ft²
- Required stopping time (t) - 1 sec

First, determine brakemotor shaft speed (N_B).

$$N_B = \frac{V}{\pi D}$$

$$= \frac{667}{\pi \times 0.25}$$

$$N_B = 849 \text{ rpm}$$

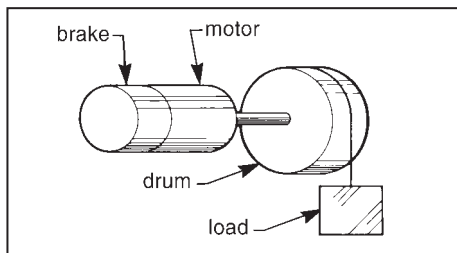

Then, determine the equivalent inertia of the overhauling load.

$$Wk_f^2 = W \left(\frac{V}{2\pi N_B} \right)^2$$

$$= 100 \left(\frac{667}{2\pi \times 849} \right)^2$$

$$Wk_f^2 = 1.56 \text{ lb-ft}^2$$

Therefore, the total inertia at the brake is,

$$Wk_f^2 = Wk_d^2 + Wk_f^2$$

$$= 5 + 1.56$$

$$Wk_f^2 = 6.56 \text{ lb-ft}^2$$

Now, the dynamic torque required to decelerate the load and drum in the required time is calculated.

$$T_d = Wk_f^2 \times N_B$$

$$= \frac{6.56 \times 850}{308 \times 1}$$

$$T_d = 18.1 \text{ lb-ft}$$

Next, calculate the dynamic torque required to overcome the overhauling load.

$$T_o = W \times R$$

$$= 100 \times \frac{0.25}{2}$$

$$T_o = 12.5 \text{ lb-ft}$$

The total dynamic torque to stop and hold the overhauling load is the sum of the two calculated dynamic torques.

$$T_t = T_d + T_o$$

$$= 18.1 + 12.5$$

$$T_t = 30.6 \text{ lb-ft}$$

Dynamic torque is then converted to static torque.

$$T_s = \frac{T_t}{0.8}$$

$$= \frac{30.6}{0.8}$$

$$T_s = 38.3 \text{ lb-ft}$$

A brake having a standard torque rating of 50 lb-ft is selected based on expected stop time. Since a brake with more torque than necessary to stop the load in 1 second is selected, the stopping time would be,

$$t = \frac{Wk_f^2 \times N}{308 \times T_d}$$

where,

$$T_s = \frac{T_t}{0.8}$$

$$= \frac{T_d + T_o}{0.8}$$

or,

$$T_d = 0.8T_s - T_o$$

$$= (0.8)(50) - 12.5$$

$$T_d = 27.5 \text{ lb-ft}$$

therefore,

$$t = \frac{6.56 \times 850}{308 \times 27.5}$$

$$t = 0.7 \text{ sec}$$

Wire the brake through a dedicated relay on overhauling loads where stop time or distance is critical. See section on *Stopping time*.

Example 8: Select a brake to stop an overhauling load driven through gear reducer in a specified time.

- Given: Motor speed (N_M) - 1,150 rpm
- Motor inertia (WK_M^2) - 0.65 lb-ft²
- Gear reduction (GR) - 300:1
- Drum diameter (D) - 1.58 ft
- Weight of load (W) - 4,940 lb
- Drum inertia (WK_d^2) - 600 lb-ft²
- Required stopping time (t) - 0.5 sec

First, calculate all inertial loads reflected to the brakemotor shaft.

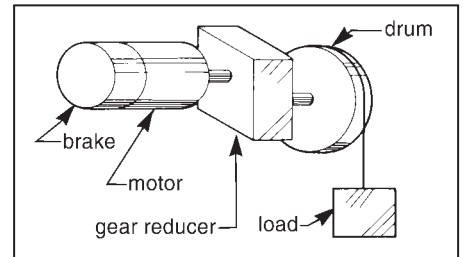

The rotational speed of the drum is,

$$N_D = \frac{N_M}{GR}$$

$$= \frac{1,150}{300}$$

$$N_D = 3.83 \text{ rpm}$$

From this, the cable speed can be determined.

$$V = N_D \times \pi D$$

$$= 3.83 \times \pi \times 1.58$$

$$V = 19.0 \text{ ft/min}$$

The equivalent inertia of the load reflected to the brakemotor shaft is,

$$Wk_f^2 = W \left(\frac{V}{2\pi N_{BM}} \right)^2$$

$$= 4,940 \left(\frac{19.0}{2\pi \times 1,150} \right)^2$$

$$Wk_f^2 = 0.034 \text{ lb-ft}^2$$

The equivalent inertia of the drum at the brakemotor shaft speed is,

$$Wk_d^2 = Wk_b^2 \left(\frac{N_D}{N_{BM}} \right)^2$$

$$= 600 \left(\frac{3.83}{1,150} \right)^2$$

Finally, the total inertia the brake will retard is,

$$Wk_f^2 = Wk_m^2 + Wk_r^2 + Wk_d^2$$

$$Wk_f^2 = 0.0067 \text{ lb-ft}^2$$

$$Wk_f^2 = 0.691 \text{ lb-ft}^2$$

The dynamic torque required to decelerate the total inertia is,

$$T_d = \frac{Wk_f^2 \times N_{BM}}{308 \times t}$$

$$= \frac{0.691 \times 1,150}{308 \times 0.5}$$

$$T_d = 5.16 \text{ lb-ft}^2$$

Now, calculate the dynamic torque to overcome the overhauling load.

$$T_o = W \times R = W \times \frac{1}{2}D$$

$$= 4,940 \times \frac{1.58}{2}$$

$$T_o = 3,903 \text{ lb-ft}$$

Which reflected to the brakemotor shaft becomes,

$$T_m = \frac{T_o}{GR}$$

$$= \frac{3,903}{300}$$

$$T_m = 13.0 \text{ lb-ft}$$

Then, the total dynamic torque to stop and hold the overhauling load is the sum of the two calculated dynamic torques.

$$T_t = T_d + T_m$$

$$= 5.16 + 13.0$$

$$T_t = 18.16 \text{ lb-ft}$$

Dynamic torque is then converted to static torque.

$$T_s = \frac{T_t}{0.8}$$

$$= \frac{18.16}{0.8}$$

$$T_s = 22.7 \text{ lb-ft}$$

A brake having a standard torque rating of 25 lb-ft is selected.

Example 9: Select a brake to stop and hold a load on an inclined plane (skip hoist).

Given: Motor data

Power (P) - 7½ hp

Speed (N_M) - 1,165 rpm

Rotor inertia (Wk_M²) - 1.4 lb-ft²

Gear reducer data:

Reduction (G_R) - 110:1

Inertia at input shaft (Wk_β²) - 0.2 lb-ft²

Drum data

Diameter (D_D) - 1.5 ft

Inertia (Wk_β²) - 75 lb-ft²

Pulley data

Diameter (D_P) - 1.5 ft

Inertia (Wk_β²) - 20 lb-ft²

Bucket weight (W_B) - 700 lb

Maximum weight of load (W_L) - 4,000 lb

Slope of track (B) - 52.7°

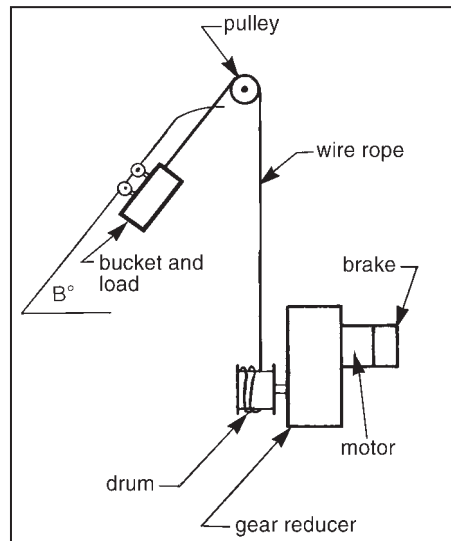

Required stopping time (t) - 1 sec

The bucket is full when ascending the track and is empty when descending. When selecting a brake the most severe condition would be a fully loaded bucket backed down the hoist track. In normal operation the descending bucket would be empty. In this example, the brake is selected for the most severe condition.

The total torque to stop and hold the bucket and load when descending is the sum of (a) the torque to decelerate the total inertia and (b) the torque required to hold the loaded bucket.

First, calculate all inertial loads reflected to the brakemotor shaft. The rotational speed of the drum is:

$$N_D = \frac{N_M}{GR}$$

$$= \frac{1,165}{110}$$

$$N_D = 10.6 \text{ rpm}$$

From this the cable speed can be determined

$$V = N_D \times \pi D_D$$

$$= 10.6 \times \pi \times 1.5$$

$$V = 50 \text{ ft/min}$$

The equivalent inertia of the loaded bucket reflected to the brakemotor shaft is,

$$Wk_f^2 = W \left(\frac{V}{2\pi N_M} \right)^2$$

$$= 4,700 \left(\frac{50}{2\pi \times 1,165} \right)^2$$

$$Wk_f^2 = 0.219 \text{ lb-ft}^2$$

Next, the inertia of the pulley and drum are reflected to the brake motor shaft speed so the total inertia at the brake can be determined.

Since the diameters of the pulley and drum are the same, 1.5 ft, their rotational speeds would be the same, 10.6 rpm.

The inertia of the pulley reflected to the brakemotor shaft is,

$$Wk_p^2 = Wk_b^2 \left(\frac{N_D}{N_M} \right)^2 = Wk_b^2 \left(\frac{1}{GR} \right)^2$$

$$= 20 \times \left(\frac{1}{110} \right)^2$$

$$Wk_p^2 = 0.0017 \text{ lb-ft}^2$$

The inertia of the drum reflected to the brakemotor shaft is,

$$Wk_d^2 = Wk_b^2 \left(\frac{N_D}{N_M} \right)^2 = Wk_b^2 \left(\frac{1}{GR} \right)^2$$

$$= 75 \times \left(\frac{1}{110} \right)^2$$

$$Wk_d^2 = 0.0062 \text{ lb-ft}^2$$

The total inertia to be stopped is,

$$Wk_f^2 = Wk_f^2 + Wk_p^2 + Wk_d^2 + Wk_m^2 + Wk_r^2$$

$$= 0.219 + 0.0017 + 0.0062 + 0.2 + 1.4$$

$$Wk_f^2 = 1.827 \text{ lb-ft}$$

Then, the dynamic torque required to bring the descending bucket and load to rest is,

$$T_d = \frac{Wk_f^2 \times N_M}{308 \times T_d}$$

$$T_d = \frac{1.827 \times 1,165}{308 \times 1}$$

The additional dynamic torque required to hold the overhauling load would be determined by the unbalanced component of the force acting along the plane of the hoist track, $W_T \sin B$, and the length of the moment arm which is the drum radius (R_D). $W_T \sin B$ is the force necessary to retard downward motion of the loaded hoist bucket.

$$\begin{aligned} T_o &= W_T \sin B \times R_D \\ &= W_T \sin B \times \frac{1}{2} D_D \\ &= 4,700 \times \sin 52.7^\circ \times \frac{1}{2} (1.5) \\ &= 4,700 \times 0.7955 \times 0.75 \\ T_o &= 2,804 \text{ lb-ft} \end{aligned}$$

Which reflected to the brakemotor shaft becomes,

$$\begin{aligned} T_m &= \frac{T_o}{GR} \\ &= \frac{2,804}{110} \\ T_m &= 25.5 \text{ lb-ft} \end{aligned}$$

Then, the total dynamic torque to stop and hold the descending bucket and load is the sum of the two calculated dynamic torques.

$$\begin{aligned} T_t &= T_d + T_m \\ &= 6.9 + 25.5 \\ T_t &= 32.4 \text{ lb-ft} \end{aligned}$$

Converting to static torque,

$$\begin{aligned} T_s &= \frac{T_t}{0.8} \\ &= \frac{32.4}{0.8} \\ T_s &= 40.5 \text{ lb-ft} \end{aligned}$$

A brake having a standard torque rating of 50 lb-ft is selected. Since a brake with more torque than necessary to stop the load in 1 second is selected, the stopping time would be,

$$\begin{aligned} t &= \frac{W_k^2 \times N_B}{308 \times T_d} \\ \text{Where, } T_s &= \frac{T_t}{0.8} \\ &= \frac{T_d + T_m}{0.8} \\ \text{or, } T_d &= 0.8 T_s - T_m \\ &= (0.8)(50) - 25.5 \\ T_d &= 14.5 \text{ lb-ft} \\ \text{therefore,} \\ t &= \frac{1.827 \times 1,165}{308 \times 14.5} \\ t &= 0.48 \text{ sec} \end{aligned}$$

See section on *Stopping time*.

Stopping Time and Deceleration Rate

In the formulas used to determine dynamic torque, stopping time or "t" in seconds is a desired or assumed value selected on the requirements of the application. For optimum brake performance, a stopping or braking time of 1 second or less is desirable. Stop times between 2 and 3 seconds require test. *A brake of insufficient torque rating will lengthen the stopping time. This may result in overheating of the brake to a point where torque falls appreciably. The friction material could carbonize, glaze, or fail.*

After determining the braking torque required by a system, it may be necessary to recalculate the stopping time based on the actual brake size selected to insure that stopping time falls within the 0 to 2 second range. Any formula, where the stopping time is a variable, may be rewritten to solve for the new stopping time. For instance, the dynamic torque equation may be transposed as follows:

$$\begin{aligned} T_d &= \frac{W_k^2 \times N_B}{308 \times t} \\ \text{or, } t &= \frac{W_k^2 \times N_B}{308 \times (0.8 \times T_s)} \end{aligned}$$

Where, t = Stopping time, sec

W_k^2 = Total inertia reflected to brake, lb-ft²

N_B = Shaft speed at brake, rpm

T_s = Nominal static torque rating of brake, lb-ft

T_d = Dynamic braking torque (0.8 x T_s), lb-ft

0.8 = Constant (derating factor)

308 = Constant

Brakes are rated in static torque. This value is converted to dynamic torque, as done in the above equation, when stopping time is calculated. That is,

$$T_d = 0.8 \times T_s$$

Where, T_d = Dynamic braking torque, lb-ft

T_s = Nominal static torque rating of brake, lb-ft

The approximate number of revolutions the brake shaft makes when stopping is:

$$\text{Revolutions to stop} = \frac{t \times N_B}{120}$$

Where, t = Stopping time, sec

N_B = Shaft speed at brake, rpm

120 = Constant

The average rate of deceleration when braking a linearly moving load to rest can be calculated using the stopping time determined by the above formula and the initial linear velocity of the load.

$$a = \frac{V_i}{t}$$

Where, a = Deceleration, ft/sec²

V_i = Initial linear velocity of load, ft/sec

t = Stopping time, sec

RPM Considerations

The maximum allowable rotational speed of the brake should not be exceeded in braking. Maximum brake rpm as listed in the catalog is intended to limit stopping time to 2 seconds or less and insure friction disc stability. Brakes are not dynamically balanced because of the low brake inertia.

Determining Required Thermal Capacity

Thermal Ratings

When a brake stops a load, it converts mechanical energy to thermal energy or heat. The heat is absorbed by components of the brake. This heat is then dissipated by the brake. The ability of a given brake to absorb and dissipate heat without exceeding temperature limitations is known as thermal capacity.

There are two categories of thermal capacity for a brake. The first is the *maximum* energy the brake can absorb in one stop, generally referred to as a "crash" or "emergency" stop. The second is the heat dissipation capability of the brake when it is cycled frequently. *To achieve optimum brake performance, the thermal rating should not be exceeded. They are specified for a predetermined maximum temperature rise of the brake friction material.*

The ability of a brake to absorb and dissipate heat is determined by many factors, including the design of the brake, the ambient temperature, brake enclosure, position of the brake, the surface that the brake is mounted to, and the altitude.

The rating for a given brake is the maximum allowable. Longer brake life results when the brake has more thermal capacity than a power transmission requires. Much shorter life or brake failure will result when the thermal capacity rating is exceeded. Ratings are determined at an ambient temperature of 72°F (22°C), with the brake in a horizontal position, with a stopping time of 1 second or less, and with no external heat source such as a motor.

Ambient temperature will limit the thermal capacity of a brake. Temperatures above 72°F (22°C) require derating of the thermal capacity rating. For example, at 150°F, thermal capacity is reduced approximately 30% (see *Derating Thermal Capacity Chart*).

CHART: Derating Thermal Capacity

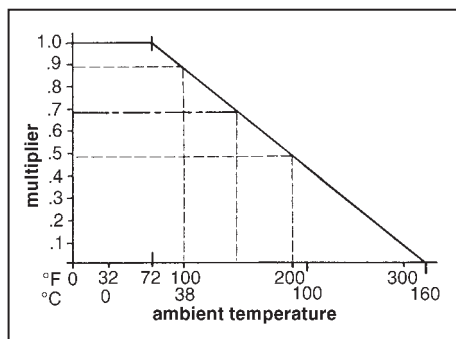

A temperature range of 20°F (0°C) to 104°F (40°C) is acceptable in most brake applications. Above 104°F also consider Class H coil insulation.

Thermal capacity ratings are determined with enclosures on the brake. Other customer furnished covers or cowls may affect a brake's thermal capacity. The effect on thermal capacity should be evaluated. In some cases, thermal capacity may be increased by use of air or liquid cooling. However, provisions must be made to prevent contaminating the brake internally.

Brakes with brass stationary discs are derated 25%.

The mounting position of a brake will also affect thermal capacity. The specified ratings are for brakes mounted in a horizontal position with the solenoid plunger above the solenoid. For brakes mounted in a vertical position, or 15° or more from horizontal, the thermal capacity decreases due to friction disc drag. Brakes are modified for vertical operation to minimize the drag. 2- and 3- disc brakes are derated 25%, 4-disc brakes are derated 33%. 4- and 5-disc brakes are not recommended for vertical use.

Thermal capacity ratings are established without external sources of heat increasing the brake temperature. The surface that a brake is mounted to, such as an electric

motor or gear reducer, will limit the heat dissipation capability or thermal capacity of a brake. These sources of heat should be evaluated when determining the thermal requirements of the system for which the brake is selected.

High altitudes may also affect a brake's thermal capacity. Stearns brakes will operate to 10,000 ft above sea level at 72°F (22°C) ambient temperature. At 104°F (40°C) ambient temperature, altitude and temperature adjustments occur. Refer to *NEMA MG1-1993 Section 14* for additional information.

CHART: Altitude & Thermal Capacity

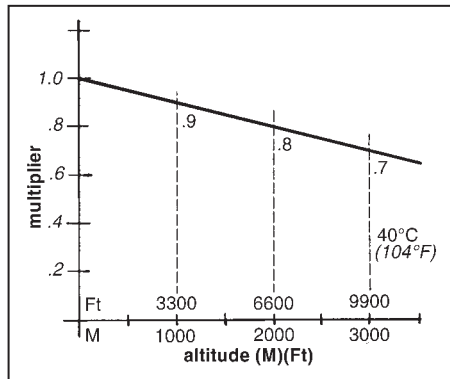

Maximum Energy Absorption

The thermal capacity of a brake is limited by the maximum energy it can absorb in one stop. This factor is important when stopping extremely high inertial loads at infrequent intervals. Such use of a brake requires extensive cooling time before it can be operated again.

The energy a brake is required to absorb in one stop by a given power transmission system is determined by the formulas below. *The calculated energy of the system should not exceed the maximum kinetic energy rating of the brake. System energy exceeding the brake's maximum rating may result in overheating of the brake to a point where torque falls appreciably. The friction material of the brake could glaze, carbonize or fail.*

In the case of linear loads, the energy that the brake must absorb is kinetic energy. It is determined by the formula:

$$KE_L = \frac{Wv^2}{2g}$$

KE_L = Kinetic energy of linear moving load, lb-ft

W = Weight of load, lb

v = Linear velocity of load, ft/sec

g = Gravitational acceleration constant, 32.2 ft/sec²

In the case of rotational loads, the energy that the brake must absorb is also kinetic energy. It is determined by the formula:

$$KE_r = \frac{Wk_f^2 \times N_b^2}{5875}$$

Where, KE_r = Kinetic energy of linear load, lb-ft

Wk_f² = Inertia of the rotating load reflected to brake shaft, lb-ft²

N_b = Shaft speed at brake, rpm

5875 = Constant

In the case of overhauling loads, both the kinetic energy of the linear and rotating loads and the potential energy transformed into kinetic energy by the change in height or position must be considered when determining the total energy that the brake must absorb. The potential energy transformed to kinetic energy is determined by the formula:

$$PE = Ws$$

Where, PE = Change in potential energy, ft-lb

W = Weight of overhauling load, lb

s = Distance load travels, ft

Thus, the total energy to be absorbed by a brake stopping an overhauling load is:

$$E_T = KE_L + KE_r + PE$$

Example 10 illustrates how energy absorption for Example 8 would be determined for one stop.

Example 10: Determine the total energy absorbed by a brake in one stop.

In Example 8, the calculation for total energy to be absorbed would be as follows.

First, calculate the kinetic energy of the linear load. The load weight was 4,940 lb and the velocity is 19 ft/min or 0.317 ft/sec. The kinetic energy is:

$$KE_L = \frac{Wv^2}{2g} = \frac{4,940 \times 0.317^2}{2 \times 32.2}$$

$$KE_L = 7.71 \text{ ft-lb}$$

Next, calculate the kinetic energy for the rotational load. The motor inertia is 0.65 lb-ft² and the drum inertia reflected to the brake shaft speed is 0.0067 lb-ft². The total rotational inertia at the brakemotor shaft is,

$$\begin{aligned} Wk_r^2 &= Wk_m^2 + Wk_d^2 \\ &= 0.65 + 0.0067 \\ Wk_r^2 &= 0.6567 \text{ lb-ft}^2 \end{aligned}$$

And the kinetic energy of the rotating components is,

$$\begin{aligned} KE_r &= \frac{Wk_r^2 \times N_B^2}{5,875} \\ &= \frac{0.6567 \times 1,150^2}{5,875} \\ KE_r &= 147.8 \text{ ft-lb} \end{aligned}$$

Now, calculate the potential energy converted to kinetic energy due to the change in position of the load while descending. A descending load is the most severe case since potential energy is transformed to kinetic energy that the brake must absorb. A 25 lb-ft brake was selected in Example 8. The 25 lb-ft static torque rating is converted to dynamic torque,

$$\begin{aligned} T_d &= T_s \times 0.8 \\ &= 25 \times 0.8 \\ T_d &= 20 \text{ lb-ft} \end{aligned}$$

Of this torque, 13.0 lb-ft is required to overcome the overhauling load as determined in Example 8. The dynamic torque available to decelerate the load is,

$$\begin{aligned} T_d &= T_t - T_m \\ &= 20 - 13 \\ T_d &= 7 \text{ lb-ft} \end{aligned}$$

The stopping time resulting from this dynamic torque is,

$$\begin{aligned} t &= \frac{Wk_r^2 \times N_B}{308 \times T_d} \\ &= \frac{0.691 \times 1,150}{308 \times 7} \\ t &= 0.369 \text{ sec} \end{aligned}$$

Where, $Wk_r^2 = 0.690 \text{ lb-ft}^2$ is the total inertia the brake is to retard as determined in Example 8. With the load traveling at 19.0 ft/min or 0.317 ft/sec, the distance it will travel is,

$$\begin{aligned} s &= \frac{1}{2} vt \\ &= \frac{1}{2} \times 0.317 \times 0.369 \\ s &= 0.059 \text{ lb-ft} \end{aligned}$$

Wire the brake through a dedicated relay on overhauling loads where stop time or distance is critical. The potential energy transformed to kinetic energy in this distance would be,

$$\begin{aligned} PE &= W_s \\ &= 4,940 \times 0.059 \\ PE &= 291 \text{ ft-lb} \end{aligned}$$

Thus, the total energy to be absorbed by the brake would be,

$$\begin{aligned} E_T &= KE_r + KE_s + PE \\ &= 7.71 + 147.8 + 291 \\ E_T &= 447 \text{ ft-lb} \end{aligned}$$

The 25 lb-ft brake selected in Example 8 should be capable of absorbing 447 ft-lb of energy. The brake's maximum kinetic energy absorption rating should exceed this value.

Motor slip and test loads (150% of load) should be considered both in sizing and thermal calculations.

Brakes overheated in testing will require inspection before using in the standard application.

Heat dissipation in cyclic applications

In general, a brake will repetitively stop a load at the duty cycle that a standard electric motor can repetitively start the load. A brake's thermal capacity is based upon the heat it can absorb and dissipate while cycling. The thermal capacity ratings for brakes are listed in the specification tables for specific brake models.

The energy that a brake is required to absorb and dissipate by a given power transmission system is determined from the total inertia of the load and system, the rotating or linear speed of the load, and the number of times the load is to be stopped in a given time period. The rate of energy dissipation is expressed in horsepower seconds per minute (hp-sec/min). Other common units for energy rates, such as foot pounds per second (ft-lb/sec), can be converted to hp-sec/min using the conversion factors given in the *Technical Data* section.

Refer to the Thermal Capacity Chart for use above 104°F (40°C) ambient temperature.

For applications demanding optimum brake performance, such as high inertial loads and frequent stops, the rate of energy dissipation required by the system is determined using the following formulas. *The calculated rate of energy dissipation should not exceed the thermal capacity of the brake. Thermal dissipation requirements exceeding the brake's rating*

may result in overheating of the brake to a point where torque falls appreciably. The friction material of the brake could glaze, carbonize or fail.

For rotating or linear loads, the rate at which a brake is required to absorb and dissipate heat when frequently cycled is determined by the relationship:

$$TC = \frac{Wk_r^2 \times N_B^2 \times n}{3.2 \times 10^6}$$

Where, TC = Thermal capacity required for rotating or linear loads
hp-sec/min

Wk_r^2 = Total system inertia reflected to brake, lb-ft²

N_B = Shaft speed at brake, rpm

n = Number of stops per minute, not less than 1

3.2×10^6 = Constant

The rotating speed enters the formula as a squared function. Therefore, thermal requirements are of particular significance in systems where the brake will be operated at high speeds.

$$TC = \frac{E_T \times n}{550}$$

Where, TC = Thermal capacity required for overhauling loads
hp-sec/min

E_T = Total energy brake absorbs, ft-lb

n = Number of stops per minute, not less than 1

550 = Constant

For overhauling loads, the rate at which a brake is required to absorb and dissipate heat when frequently cycled is determined by the relationship:

Example 11 illustrates how the required thermal capacity would be determined for Example 4.

Example 11: Determine the thermal capacity required to stop a rotating load frequently.

Referring back to Example 4, the flywheel will be stopped 20 times per minute. The required thermal capacity of the 6 lb-ft brake selected in this example is determined as follows.

The total inertial load the brake is to retard is 0.15 lb-ft². The shaft speed of the brake motor is 1,800 rpm. Therefore, the required thermal capacity is,

$$\begin{aligned} TC &= \frac{Wk_r^2 \times N_B^2 \times n}{3.2 \times 10^6} \\ &= \frac{0.15 \times 1,800^2 \times 20}{3.2 \times 10^6} \end{aligned}$$

TC = 3.0 hp-sec/min

The 6 lb-ft brake selected in Example 4 should have a thermal capacity rating equal to or greater than 3.0 hp-sec/min.

A brake with greater thermal capacity will result in greater wear life.

If productivity is to be improved in Example 4 by increasing the cycle rate, the maximum number of stops per minute is determined by the rated thermal capacity of the brake. If the 6 lb-ft brake selected in Example 4 has rated thermal capacity of 9 hp-sec/min, the maximum permissible stops per minute would be determined by transposing the above formula to,

$$\begin{aligned}n_{\max} &= \frac{TC_{\text{rated}} \times (3.2 \times 10^6)}{Wk_f^2 \times N_{\text{M}}^2} \\ &= \frac{9 \times (3.2 \times 10^6)}{0.15 \times 1,800^2} \\ n_{\max} &= 59 \text{ stops/min}\end{aligned}$$

So, the brake could be operated up to 36 times per minute without exceeding its ability to absorb and dissipate the heat generated by the frequent stops and meet the maximum solenoid cycle rating. *Cycle rate cannot exceed the solenoid cycle rate appearing in the catalog.*

Electrical Considerations

Please see page 118.

Environmental Considerations

Brakes with standard open enclosures when mounted on NEMA C-face motors are drip-proof, except where a manual release lever has a clearance opening in the housing. The standard enclosure is commonly used on open, drip-proof and enclosed motors operating indoors or in protected outdoor environments.

NEMA 4, IP 54 enclosures are available on most brake models and are commonly used for outdoor installations, or where there are moist, abrasive or dusty environments. Standard and severe duty NEMA 4 enclosures are available in some brake series.

Brakes of various styles and materials for above or below deck on ships and dockside installation are available. The materials are usually specified by the ship designers or Navy specification MIL-B-16392C. Brakes are also available to meet MIL-E-17807B for shipboard weapon and cargo elevators. Refer to *Marine, Maritime and Navy Catalog* pages.

Brakes Listed by Underwriters Laboratories, Inc. and certified by Canadian Standards Association are available for use in hazardous locations, including Class I, Groups C and D; and Class II, Groups E, F and G. *Motor-mounted*, hazardous-location electric disc brakes are listed only when mounted to a Listed hazardous-location motor of the same Class and Group at the motor manufacturer's facility, and where the combination has been accepted by UL or CSA. This procedure completes the hazardous duty assembly of the brake. However, foot-mounted hazardous-location disc brakes that are Listed are also available for coupling to a motor, and may be installed by anyone.

Hazardous-location brakes are *not* gasketed unless indicated in the brake description. The enclosure prevents flame propagation to the outside atmosphere through controlled clearances. Protection from weather and washdowns must be provided. If the brake is used in a high humidity or low temperature environment, internal electric heaters should be used.

Standard ambient temperature range for brake operation is from 20°F (0°C) to 104°F (40°C). Refer to *Thermal Ratings* section for brake operation at higher ambient temperatures. Heaters may be available for brake operation at low ambient temperatures and high humidity environments. Ductile iron construction and heaters are recommended for prolonged cold climate use.

Conclusion

The spring-set, electrically released disc brake is an important accessory to electric motors used in cycling and holding operations. It is available in a wide variety of enclosures. In most applications, a brake requires no additional wiring, controls or auxiliary electrical equipment. It is simple to maintain since the replaceable items, the friction discs, can be easily changed.

Many spring-set motor brakes are equipped with features such as simple wear adjustment to provide optimum friction disc life, visual wear indicator, torque adjustment and manual release. Featured on some types of brakes is automatic adjustment to compensate for friction disc wear. This feature eliminates the need for periodic adjustment and is advantageous in remote or inaccessible locations. Not all of the brakes on the market provide all of these features, but there are many Stearns motor brakes offering these features.

Care should be exercised in properly selecting a brake giving due consideration to torque as well as environment and thermal requirements.

On applications where all the pertinent information is not available, selection must be based on previous experience of the designer and user, as well as the brake manufacturer, and should be confirmed by tests under actual operating conditions. If the brake is selected with reasonable allowances made for extremes in operating conditions, it will perform its task with little attention or maintenance.

Formulas

The following formulas cover the basic calculations used in brake application engineering.

Required	Given	Formula
Full load motor torque (T_{fimt}), lb-ft	Horsepower (P), hp Shaft speed (N), rpm 5252 = Constant	$T_{fimt} = \frac{5252 \times P}{N}$
Average dynamic braking torque (T_d), lb-ft	Total inertia reflected to brake (Wk^2), lb-ft ² Shaft speed at brake (N), rpm Desired stopping time (t), seconds 308 = Constant	$T_d = \frac{Wk^2 \times N}{308 \times t}$
Static torque (T), lb-ft	Force (F), lb Pulley or drum radius, (R), ft	$T = F \times R$
Overhauling dynamic torque reflected to brake shaft (T_o), lb-ft	Weight of overhauling load (W), lb Linear velocity of descending load (V), ft/min Shaft speed at brake (N), rpm 0.158 = Constant	$T_o = \frac{0.158 \times W \times V}{N}$
Static torque of brake (T_s), lb-ft (General Guideline)	Dynamic braking torque required (T_d), lb-ft 0.8 = Constant (derating factor)	$T_s = \frac{T_d}{0.8}$
Inertia of rotating load reflected to brake shaft (Wk_b^2), lb-ft ²	Inertia of rotating load (Wk_L^2), lb-ft ² Shaft speed at load (N_L), rpm Shaft speed at brake (N_B), rpm	Equivalent $Wk_b^2 = Wk_L^2 \left(\frac{N_L}{N_B} \right)^2$
Equivalent inertia of linear moving load reflected to brake shaft (Wk_w^2), lb-ft ²	Weight of linear moving load (W), lb Linear velocity of load (V), ft/min Shaft speed at brake (N_B), rpm 2π = Constant	Equivalent $Wk_w^2 = W \left(\frac{V}{2\pi N_B} \right)^2$
Kinetic energy of rotating load, (KE_r), ft-lb	Inertia of rotating load reflected to brake shaft (Wk_b^2), lb-ft ² Shaft speed at brake (N_B), rpm 5875 = Constant	$KE_r = \frac{Wk_b^2 \times N_B^2}{5875}$
Kinetic energy of linear moving load (KE_l), ft-lb	Weight of load (W), lb Linear velocity of load (v), ft/sec g = Gravitational acceleration constant, 32.2 ft/sec ²	$KE_l = \frac{Wv^2}{2g}$
Change in potential energy (PE), ft-lb	Weight of overhauling load (W), lb Distance load travels (s), ft	$PE = Ws$
Total energy absorbed by brake (E_T), ft-lb	Total linear kinetic energy, (KE_L), ft-lb Total rotary kinetic energy (KE_R), ft-lb Potential energy converted to kinetic energy (PE), ft-lb	$E_T = KE_L + KE_R + PE$
Thermal capacity required for rotational or linear moving loads (TC), hp-sec/min	Total system inertia reflected to brake shaft (Wk_T^2), lb-ft ² Shaft speed at brake (N_B), rpm Number of stops per minute (n), not less than one 3.2×10^6 = Constant	$TC = \frac{Wk_T^2 \times N_B^2 \times n}{3.2 \times 10^6}$
Thermal capacity required for overhauling loads (TC), hp-sec/min	Total energy brake absorbs (E_T), ft-lb Number of stops per minute (n), not less than one 550 = Constant	$TC = \frac{E_T \times n}{550}$
Linear velocity, ft/min	N = rpm Diameter (D), ft	$V = N\pi D$